

DOORS AND MANWAYS

MANNLOCHTÜREN UND KLAPPTÜREN



02 PIPE UNIONS
ROHRVERBINDUNGEN



06 DOORS AND MANWAYS
MANNLOCHTÜREN UND KLAPPTÜREN



03 FITTINGS
ROHRFORMSTÜCKE

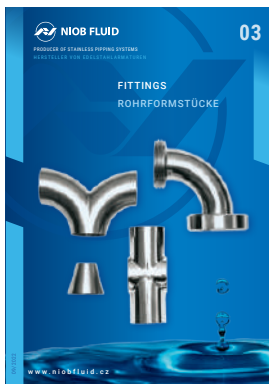

07 ACCESSORIES
ZUBEHÖR



04 VALVES AND COCKS
VENTILE UND HÄHNNE



08 DOUBLE-WALLED PIPING SYSTEMS
DOPPELWANDIGE ROHRSYSTEME

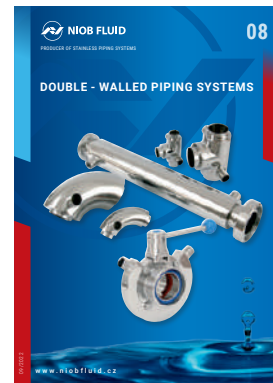

05 SPECIAL FITTINGS AND PARTS
SPEZIALARMATUREN UND TEILE



09 ASEPTIC PROGRAM
ASEPTISCHES PROGRAMM





The company NIOB FLUID s. r. o. is a manufacturer focused on the production of fasteners, shut-off and control valves of stainless steels. These valves are especially designed for the transport of liquids in the food, chemical and the pharmaceutical industry. It is simultaneously also the supplier of pipe fittings and other parts needed for piping systems and components for tanks such as the lid, manwaydoor, level indicator and other components.

Die Gesellschaft NIOB FLUID s.r.o. ist ein Hersteller, der auf die Produktion von Verbindungs-, Absperr- und Regulierungsarmaturen aus Edelstahl orientiert ist. Diese Armaturen sind vor allem für den Transport von Flüssigkeiten in der Lebensmittel- und Chemieindustrie und in der Pharmazie bestimmt. Die Gesellschaft ist gleichzeitig auch Lieferant von Rohrverbindungsstücken und weiteren Teilen, die für die Rohrleitungen erforderlich sind, und von Behälterteilen wie Hauben, Luken, Standgläser und weitere Komponenten.

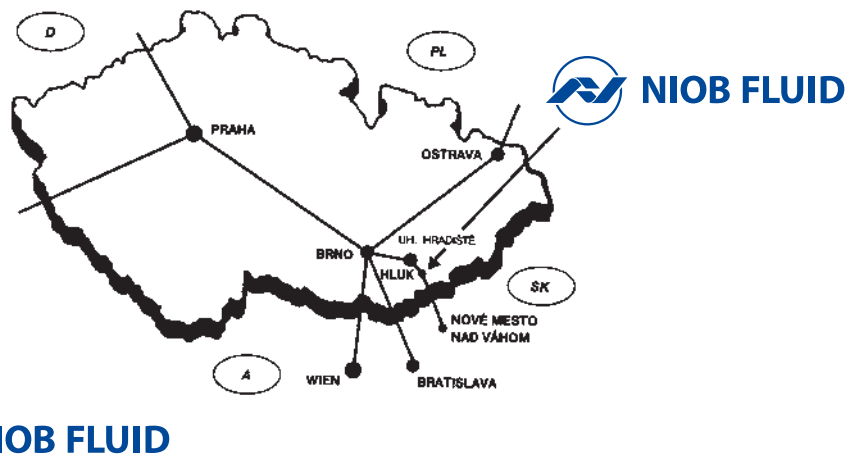

NIOB FLUID s. r. o.

Ostrožská 1003, 687 25 Hluk, Czech Republic

Phone: +420 572 419 822 – 8, Fax: +420 572 419 868

E-mail: marketing@niobfluid.cz, www.niobfluid.cz



DOORS AND MANWAYS

By means of its new catalogue of manways and doors, NIOB FLUID s.r.o. can offer a large range of available products which characterize themselves for their quality and sturdiness. To give more and more an efficient service we report herewith some technical indications to follow. On all our manways and doors, all the components like screws, stirrups and arms which do not get in touch with the final product are made of in AISI 304 material. The standard gaskets are made of rubber fit to get in contact with soft foods reaching max 50°C / min. 18°C temperature. We can offer gaskets in Viton, Silicone, NBR, EPDM and other polymers available on request. It is mainly important to find the suitable polymer for the right liquid in order to avoid both temperature problems and composition problems of the product. A temperature chart giving some indications on the recommended polymers is available in the catalogue. FDA certifications are also available. The standard finishing of the frame is scouring, sand-blasted or glazed ($Ra \pm 1,6$) – The cover is mirror polished with a middle wrinkledness $Ra < 0,4$. We can offer both frames and covers with electrolytic finishing or with mirror polished medium wrinkledness finishing $Ra < 0,8$. The keeping pressure on manways and doors, the expansion and burst tests reported in this catalogue have been made during the prototype phase of the final product with air and water reaching + 15°C. The pressure information reported on every article "P. max bar", states for the maximum static pressure that our manholes and doors can bear. The accidental overcoming of the suitable pressure can also irreparably damage the product causing a loss of it. The suitable pressure doesn't consider the deformations caused by following welding phases of the product or by wrong effected assemblage, or even the product wrong application on substances which are not suitable for the right use of the product (see chart of resistance polymers). We recommend a correct maintenance and a periodic substitution of the elements which are always in contact with the liquid as guarantee of a good use of our manholes and during doors the years (see parts of exchange). Veneta Acciai Srl doesn't guarantee its products if the above mentioned instructions are not implemented by both manufacturer's plant or artifact, and by the end user.

MANNLOCHTÜREN UND KLAPPTÜREN

Die Firma NIOB FLUID stellt mit diesem neuen Katalog von Mannloch- und Klapptüren eine große Auswahl von Artikeln zur Verfügung, die von ihrer Qualität und ihrer Widerstandskraft gekennzeichnet sind. Wir geben hiermit einige grundsätzliche technische Hinweise, um eine immer mehr leistungsfähige Dienstleistung zu gewähren, wie folgt. Bei allen unseren Mannloch- und Klapptüren werden die Verschraubungen, die Pratzen und Ärmel, die nicht medienberührt sind, aus AISI 304 erzeugt. Die verwendeten Standard-Dichtungen sind aus einem Gummimaterial, welches für die Berührung mit nicht aggressiven Nahrungsmitteln bei einer Temperatur von max 50°C / min. 18°C geeignet ist. Auf Anfrage können wir Dichtungen in Viton, Silikon, NBR, EPDM und anderen Polymeren im Handel liefern. Es ist sehr wichtig, ein Polymer geeignet für das Produkt, das zu enthalten ist, zu bestimmen, da hier große Probleme mit der Temperatur oder mit der Komposition des Produkts entstehen können. Im Katalog gibt's dafür eine Tabelle, die grundsätzliche Angaben über die Gebrauchstemperatur und über die empfohlene Polymere enthält. Unsere Firma kann die Zertifikate nach FDA gewähren. Die Standard-Fertigbearbeitung des Rahmens ist gebeizt, sandstrahlt oder satiniert ($Ra \pm 1,6$) – Der Deckel ist glatt, mit einem Mittenrauhwert $Ra < 0,4$. Auf Anfrage können wir die Rahmen und die Deckel mit elektrischer Fertigbearbeitung oder mit glatter Fertigbearbeitung vom Mittenrauhwert $Ra < 0,8$ liefern. Die Druckdichtheitsprüfung, die Prüfungen der Ausdehnung und nachfolgender Berstversuch auf den Mannloch- und Klapptüren, die in diesem Katalog angeführt sind, wurden in der Prototyp-Phase des Produktes mit Luft und Wasser bei der Temperatur von + 15°C durchgeführt. Die Angabe über dem Druck, die auf jedem Artikel als "P. max bar" gezeichnet ist, zeigt den größten statischen Druck, den die Mannloch- und Klapptüre ertragen können. Eine auch zufällige Überschreitung des angegebenen Druckwertes kann das Produkt auf unersetzlicher Weise beschädigen und einen Verlust des Inhaltes verursachen. Der angegebene Druck beachtet nicht die mögliche Verziehen, die nachfolgend vom Schweißen verursacht sind, oder vom nicht richtigen Zusammenbau, sowie von der Anwendung des Produktes in den Anlagen oder mit den Substanzen, die für dieses nicht geeignet sind (Siehe Tabelle von Polymerenwiderstand). Als Garantie für einen guten Gebrauch von unseren Mannloch- und Klapptüren empfehlen wir eine richtige Wartung und einen periodischen Ersatz von den medienberührten Teilen (Siehe Ersatzteile). Die Firma Veneta Acciai übernimmt keine Gewährleistung bei nicht sachgerechter Verwendung oder Anwendung.vv



Oval manwaydoor inwards opening – PED
Ovale Mannlochdeckel schwenkbar nach innen – PED

6001

340 x 440 mm **AISI 304 - 316L**

- ① frame - kragen
- ② cover - deckler
- ③ gasket - dichtung
- ④ handwheel - hanggrift
- ⑤ transom - riegel

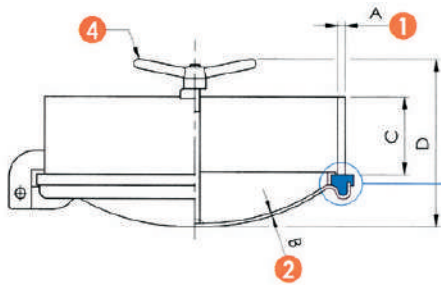
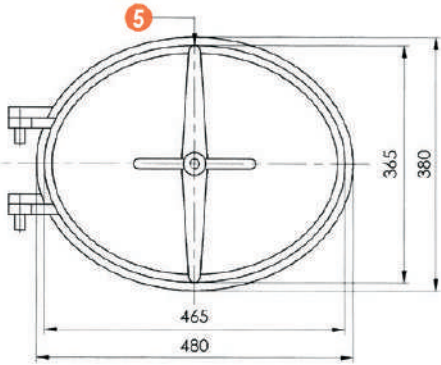

ART.	A	B	C	D	P. max bar	CER.
6001	12	5	120	265	10	PED
6001 R	8	3	80	225	6	-

Oval manwaydoor inwards opening
Ovale Mannlochtür, Öffnung nach Innen

6003

410 x 510 mm **AISI 304 - 316L**

- ① frame - kragen
- ② cover - deckler
- ③ gasket - dichtung
- ④ handwheel - hanggrift
- ⑤ transom - riegel
- ⑥ arm - schulter

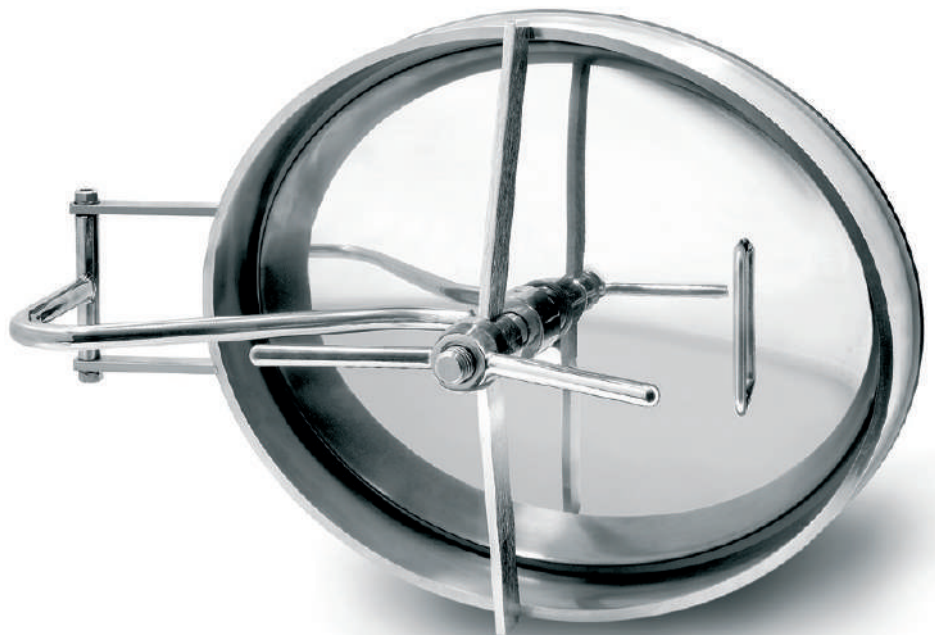
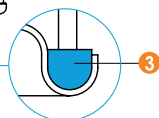
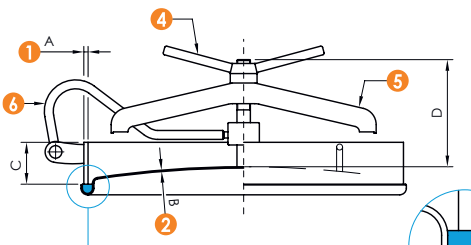
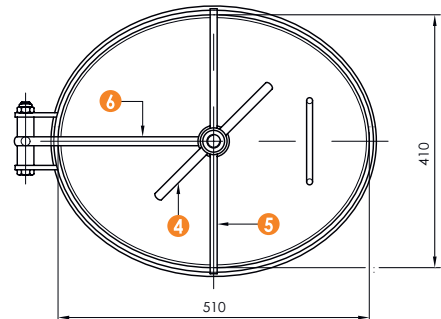

ART.	A	B	C	D	P. max bar
6003	10	3	80	160	6



Oval manwaydoor inwards opening
Ovale Mannlochtür, Öffnung nach Innen

6003 A

410 x 510 mm **AISI 304 - 316L**

- ① frame - kragen
- ② cover - deckler
- ③ gasket - dichtung
- ④ handwheel - hanggriff
- ⑤ transom - riegel

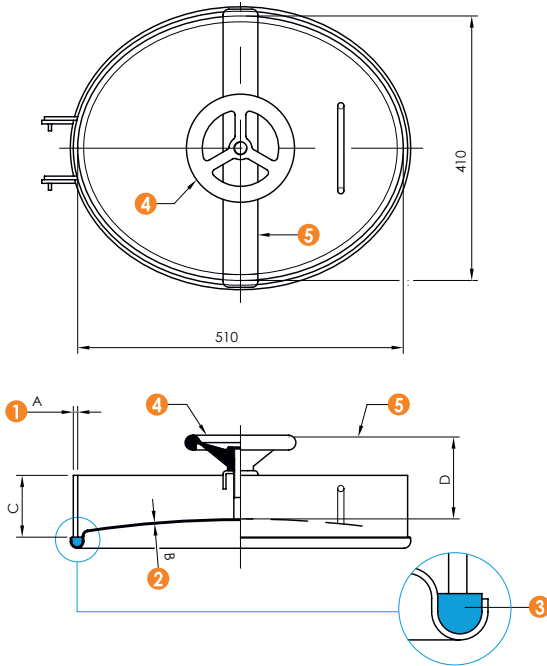

ART.	A	B	C	D	P. max bar
6003 A	10	3	80	~160	6

Oval manwaydoor inwards opening
Ovale Mannlochdeckel schwenkbar nach innen

6004

350 x 450 mm **AISI 304 - 316L**

- ① frame - kragen
- ② cover - deckler
- ③ gasket - dichtung
- ④ handwheel - hanggriff
- ⑤ transom - riegel

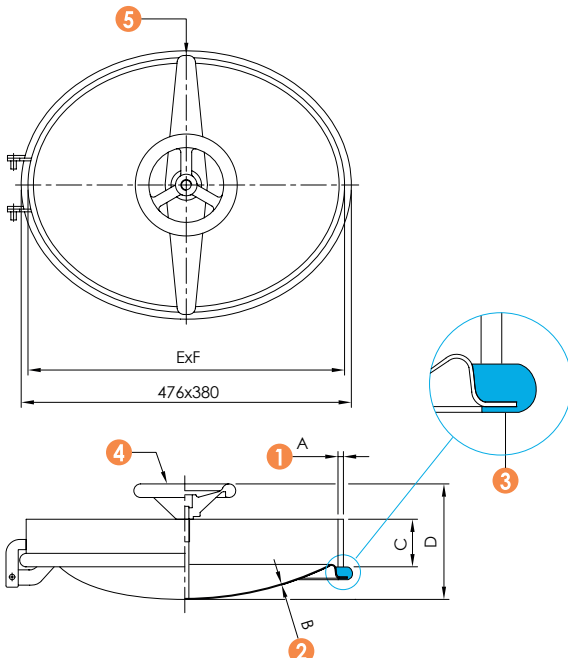
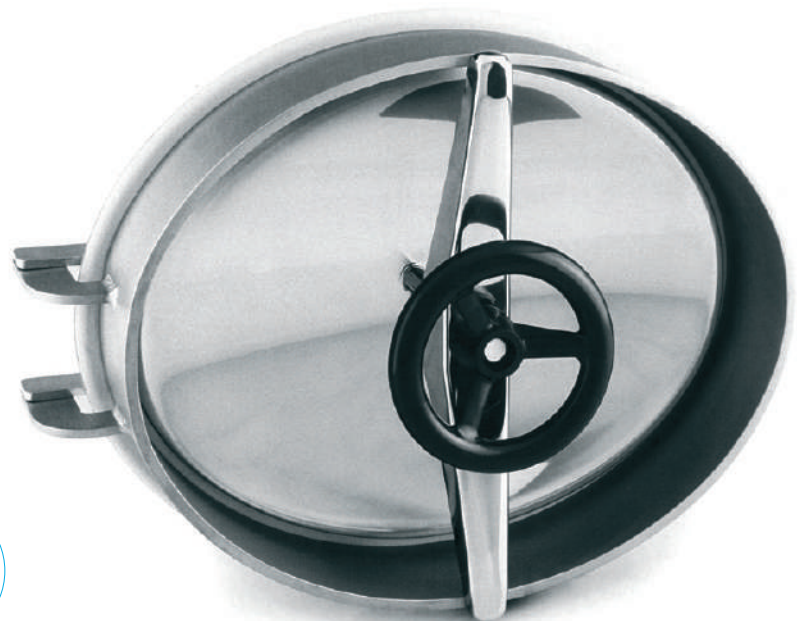

ART.	A	B	C	D	ExF	P. max bar
6004	8	2	80	175	468x374	3
6004 SUPER	12	3	80	175	474x380	4

6004 B - Cover only complete with acc. / Lediglich Deckel komplett mit Zubehör



Oval manwaydoor inwards opening
Ovale Mannlochdeckel schwenkbar nach innen

6005

350 x 450 mm **AISI 304 - 316L**

- ① frame - kragen
- ② cover - deckler
- ③ gasket - dichtung
- ④ handwheel - hanggrift
- ⑤ transom - riegel
- ⑥ arm - schulter

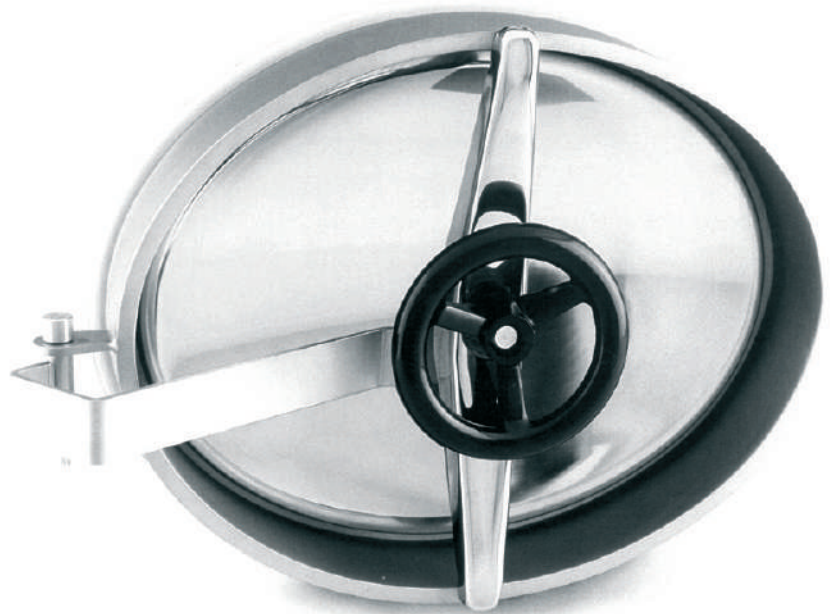
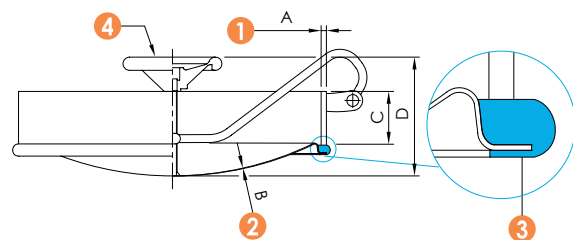
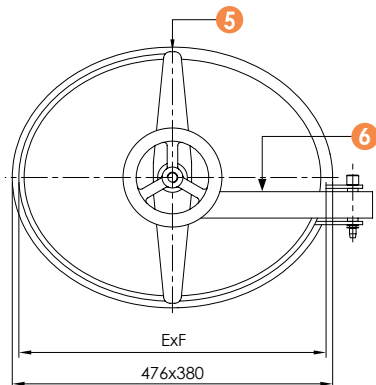

ART.	A	B	C	D	ExF	P. max bar
6005	8	2	80	175	468x374	3
6005 SUPER	12	3	80	175	474x380	4

6005 B - Cover only complete with acc. / Lediglich Deckel komplett mit Zubehör

Oval manwaydoor inwards opening
Ovale Mannlochdeckel schwenkbar nach innen

6006

310 x 445 mm **AISI 304 - 316L**

- ① frame - kragen
- ② cover - deckler
- ③ gasket - dichtung
- ④ handwheel - hanggrift
- ⑤ transom - riegel

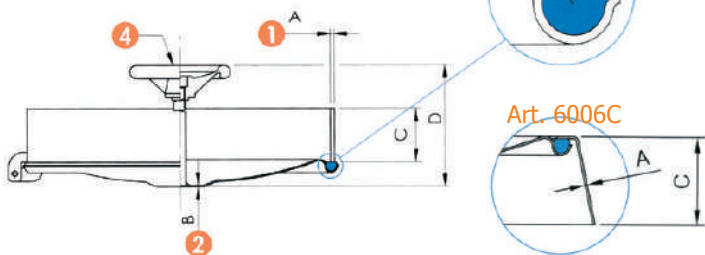
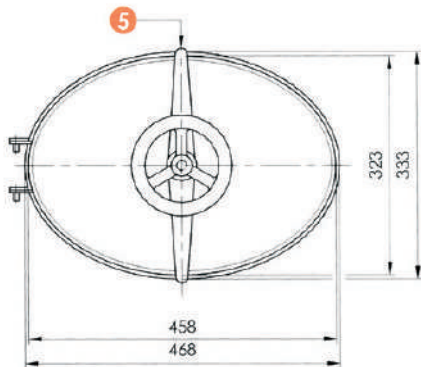

ART.	A	B	C	D	P. max bar
6006	6	2	60	120	2
6006 A	6	2	80	140	2
6006 SUPER	8	2	60	120	2
6006 A SUPER	8	2	80	140	2

6006 B - Cover only complete with acc. / Lediglich Deckel komplett mit Zubehör



Oval manwaydoor inwards opening
Ovale Mannlochtür schwenkbar nach innen

6006 D

315 x 412 mm **AISI 304 - 316L**

- ① frame - kragen
- ② cover - deckler
- ③ gasket - dichtung
- ④ handwheel - hanggrift
- ⑤ transom - riegel

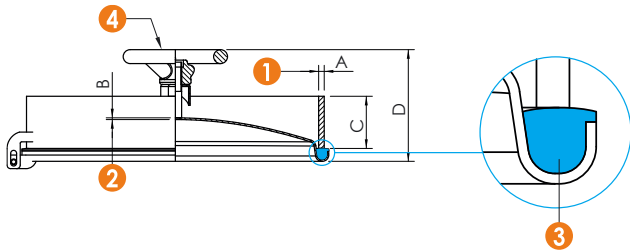
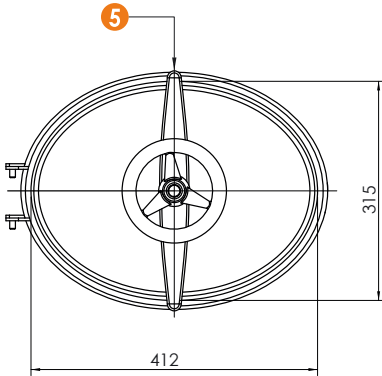

ART.	A	B	C	D	P. max bar
6006 D	8	2,5	75	160	4

Oval manwaydoor inwards opening
Ovale Mannlochtür schwenkbar nach innen

6006 D1

315 x 412 mm **AISI 304 - 316L**

- ① frame - kragen
- ② cover - deckler
- ③ gasket - dichtung
- ④ handwheel - hanggrift
- ⑤ transom - riegel
- ⑥ arm - schulter

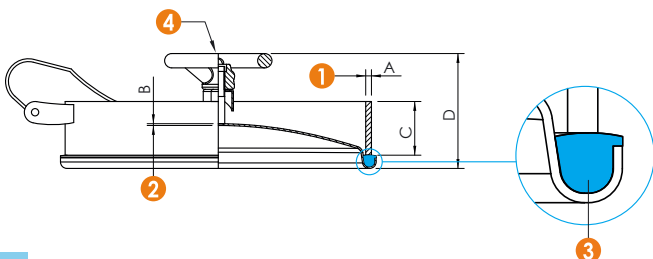
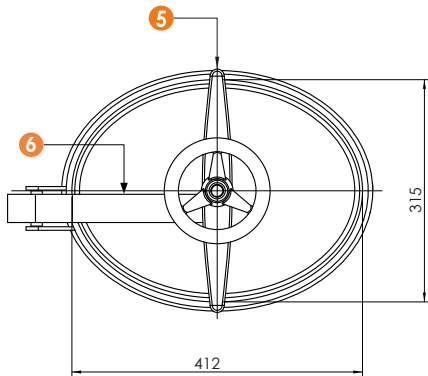

ART.	A	B	C	D	P. max bar
6006 D1	8	2,5	75	160	4



Oval manwaydoor inwards opening
Ovale Mannlochdeckel schwenkbar nach innen

6007

310 x 445 mm **AISI 304 - 316L**

- ① frame - kragen
- ② cover - deckler
- ③ gasket - dichtung
- ④ handwheel - hanggrift
- ⑤ transom - riegel
- ⑥ arm - schulter

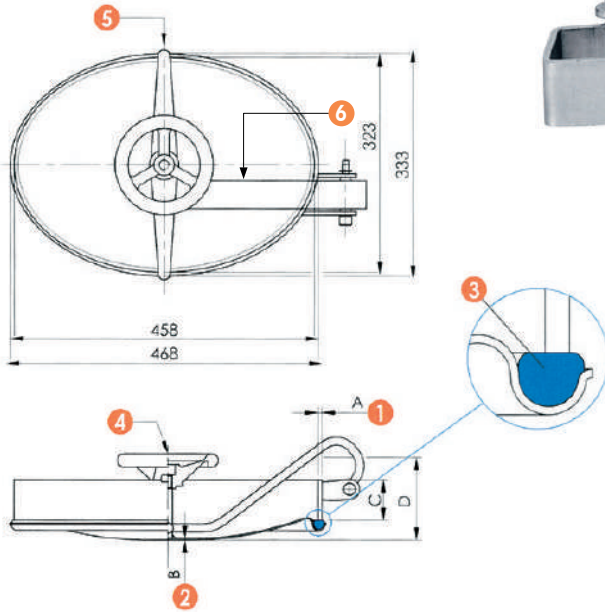

ART.	A	B	C	D	P. max bar
6007	6	2	60	120	2
6007 A	6	2	80	140	2
6007 SUPER	8	2	60	120	2
6007 A SUPER	8	2	80	140	2

6007 B - Cover only complete with acc. / Lediglich Deckel komplett mit Zubehör

Oval manwaydoor outwards opening
Ovale Mannlochdeckel, Öffnung nach außen

6007 D

310 x 445 mm **AISI 304 - 316L**

- ① frame - kragen
- ② cover - deckler
- ③ gasket - dichtung
- ④ handwheel - hanggrift
- ⑤ arm - schulter

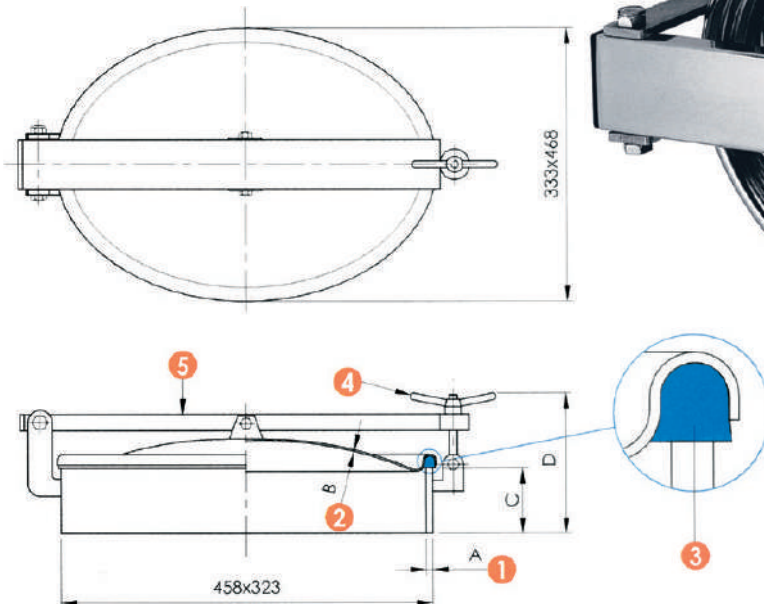

ART.	A	B	C	D	P. max bar
6007 D	6	2	80	195	0,1

6007 E - Cover only complete with acc. / Lediglich Deckel komplett mit Zubehör



Oval manwaydoor outwards opening with insulated lid
Ovale mannlochur Öffnung nach außen mit isolierterm Deckel

6007 G

AISI 304 - 316L

- 1 frame - kragen
- 2 cover - deckler
- 3 gasket - dichtung
- 4 handwheel - hanggrift
- 5 arm - schulter

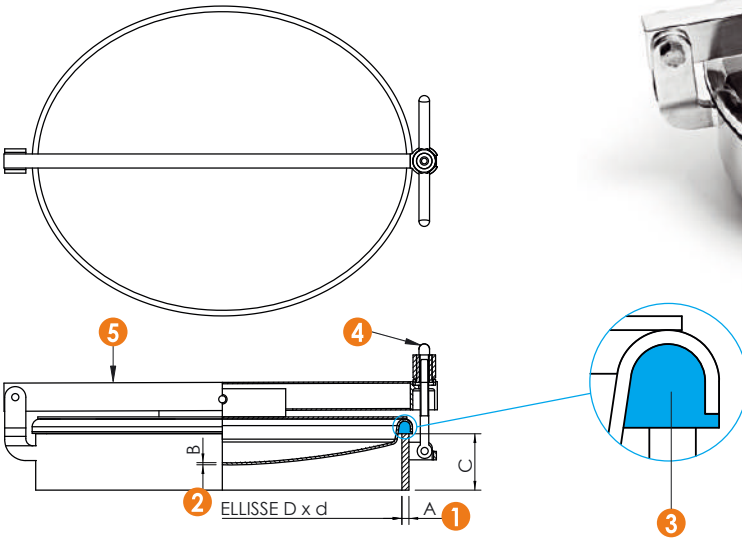

ART.	Dxd	LAYOUT	A	B	C	P. max bar	Vacuum bar
6007 G	412x315		8	2,5	75	0,3	-1
6007 GV	412x315		8	2,5	75	0,2	-1
6007 G1	510x410		10	3	80	0,1	-1
6007 G1V	510x410		10	3	80	0,08	-1

Oval manwaydoor inwards opening
Ovale Mannlochdeckel schwenkbar nach innen

6007 P

410 x 540 mm AISI 304 - 316L

- 1 frame - kragen
- 2 cover - deckler
- 3 gasket - dichtung
- 4 handwheel - hanggrift
- 5 transom - riegel

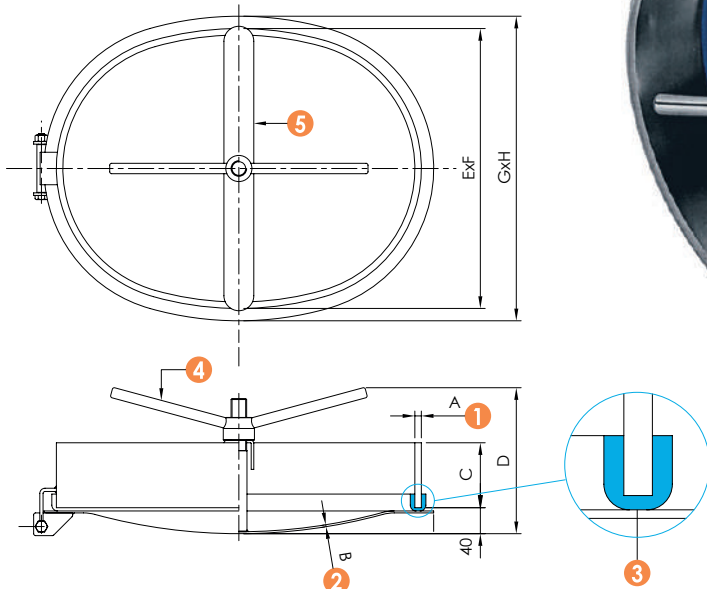

ART.	A	B	C	D	ExF	GxH	P. max bar
6007 P MINI	6	3	80	170	458x323	475x345	1,5
6007 P MAXI	10	3	100	210	562x431	610x479	1,2
6007 P MAXI SUPER	10	4	100	210	562x431	610x479	1,8



Cover portela for insulation
Deckel - Tür zur Isolierung

6007 F

435 x 590 mm **AISI 304 - 316L**

- ① - frame - kragen
- ② - cover - deckler
- ③ - gasket - dichtung

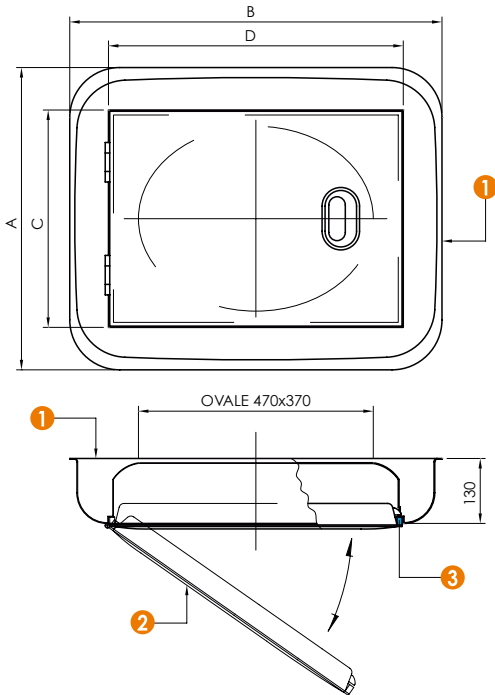

ART.	A	B	C	D
6007 F	605	745	435	590



Oval manwaydoor inwards opening
Ovale Mannlochdeckel schwenkbar nach innen

6008

340 x 440 mm **AISI 304 - 316L**

- ① frame - kragen
- ② cover - deckler
- ③ gasket - dichtung
- ④ handwheel - hanggrift
- ⑤ transom - riegel
- ⑥ arm - schulter

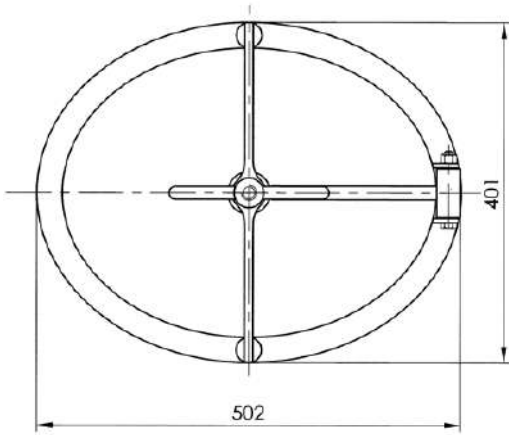

Art. 6008

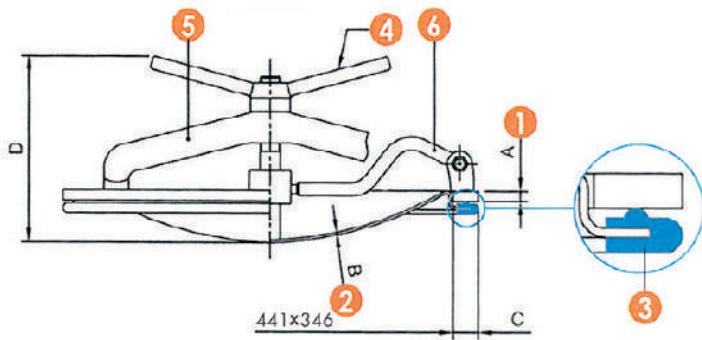

Art. 6008C

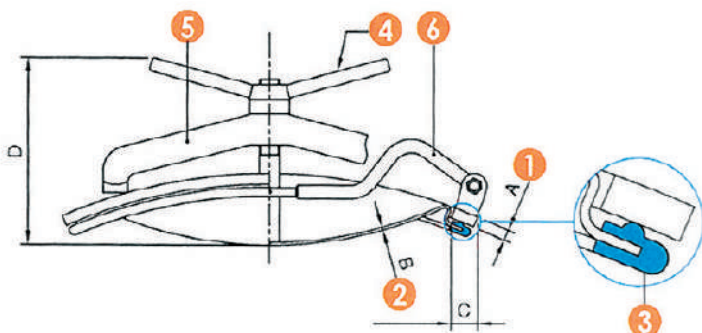

ART.	A	B	C	D	P. max bar
6008	12	3	30	230	4
6008 C	Radius on demand for various tank diametres min. Ø 1300				



Oval manwaydoor inwards opening
Ovale Mannlochtür, Öffnung nach Innen

6008 ECO

340 x 440 mm **AISI 304 - 316L**

- ① frame - kragen
- ② cover - deckler
- ③ gasket - dichtung
- ④ handwheel - handgrift
- ⑤ transom - riegel

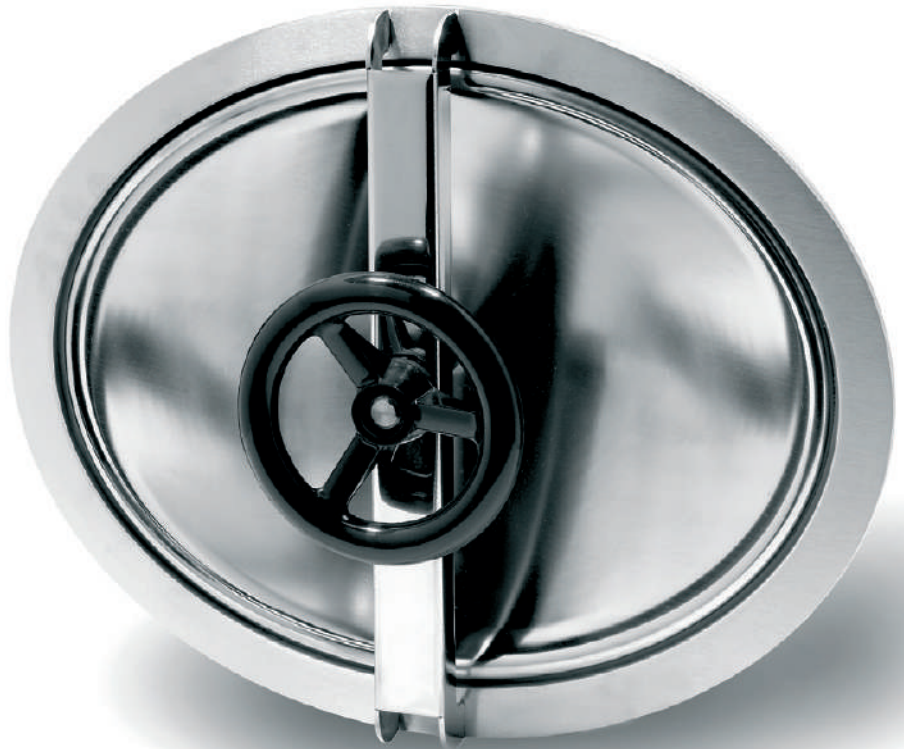

Art. 6008 ECO

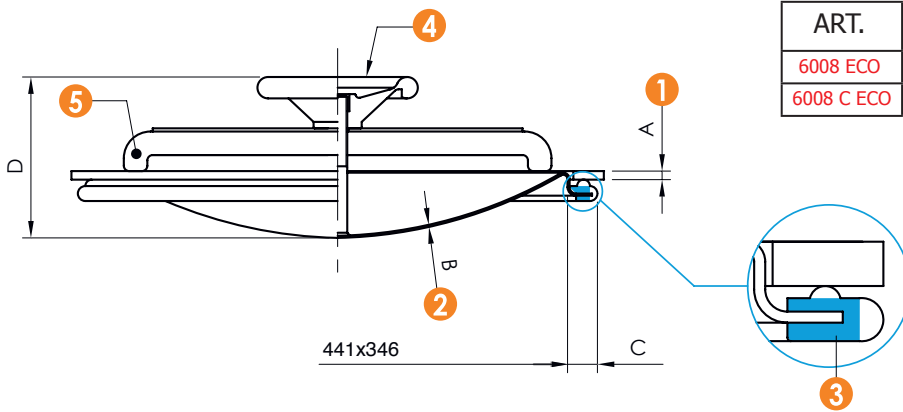

ART.	A	B	C	D	P. max bar
6008 ECO	8	2	30	~ 150	2,5
6008 C ECO	Radius on demand for various tank diametres min. Ø 1300				

Art. 6008C ECO

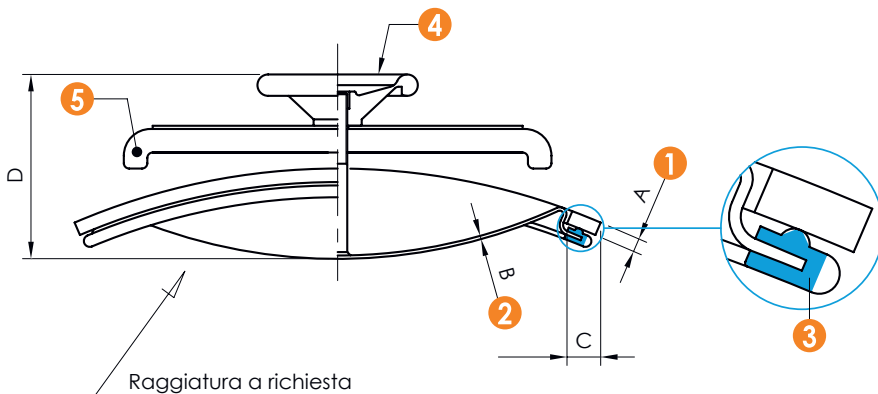



Oval manwaydoor inwards opening
Ovale Mannlochdeckel schwenkbar nach innen

6009 A

340 x 440 mm **AISI 304 - 316L**

- ① frame - kragen
- ② cover - deckler
- ③ gasket - dichtung
- ④ handwheel - handgrift
- ⑤ transom - riegel
- ⑥ arm - schulter

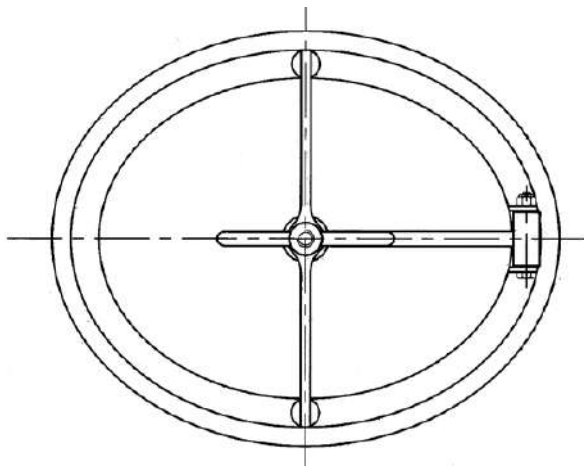

ART.	A	B	C	D	P _{max} bar
6009 A	3	3	30	230	4

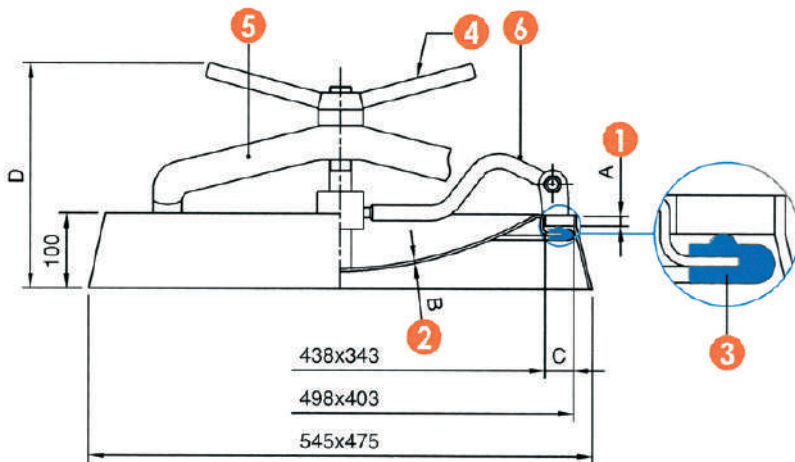



Oval manwaydoor inwards opening
Ovale Mannlochtür, Öffnung nach Innen

6009 ECO

340 x 440 mm **AISI 304 - 316L**

- ① frame - kragen
- ② cover - deckler
- ③ gasket - dichtung
- ④ handwheel - hanggrift
- ⑤ transom - riegel

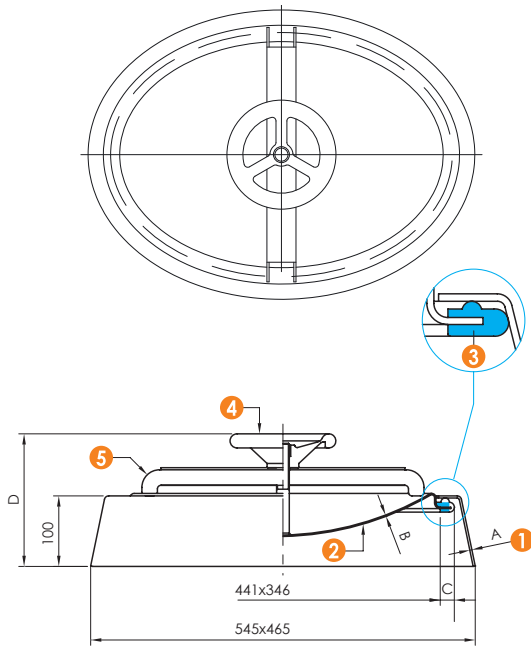

ART.	A	B	C	D	P. max bar
6009 ECO	3	2	30	188	2,5

Rectangular manwaydoor outwards horizontal opening
Rechteckige Mannlochdeckel, waagerechte außen Öffnung

6009 H

AISI 304 - 316L

- ① frame - kragen
- ② cover - deckler
- ③ gasket - dichtung
- ④ handwheel - hanggrift
- ⑤ arm - schulter

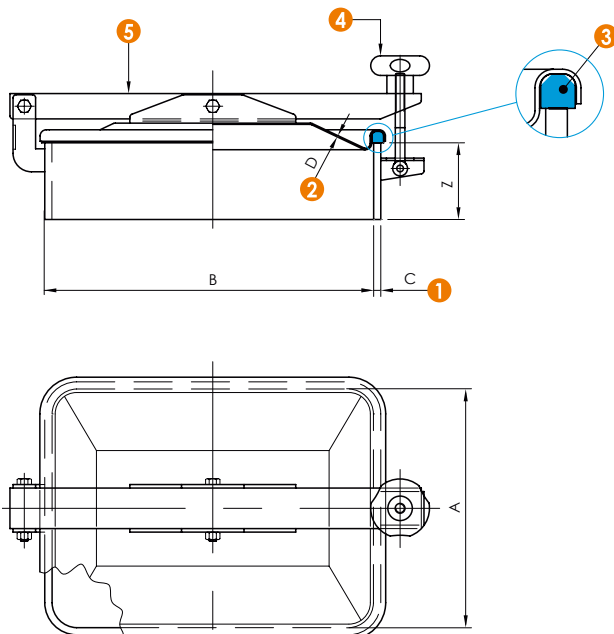

ART.	A	B	C	D	P. max bar
6009 H	175	225	6	50	0,5
6009 H-1	246	313	6	50	0,4
6009 H-2	275	365	6	50	0,2
6009 H-3	275	405	6	50	0,1



Rectangular manwaydoor outwards opening
Rechteckige Mannlochdeckel, Öffnung nach außen

6010

310 x 420 mm **AISI 304 - 316L**

- 1 frame - kragen
- 2 cover - deckler
- 3 gasket - dichtung
- 4 handwheel - hanggrift
- 5 arm - schulter

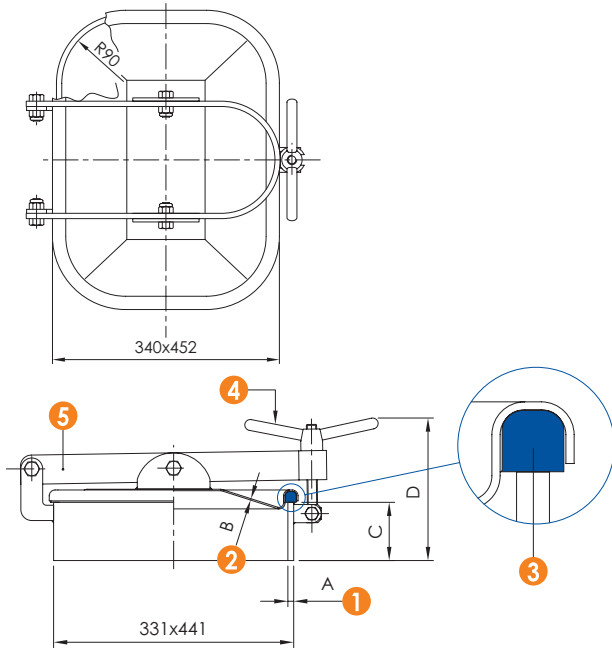

ART.	A	B	C	D	P. max bar
6010	8	2	80	200	0,5
6010 B - Cover only complete with acc. / Lediglich Deckel komplett mit Zubehör					

Rectangular manwaydoor outwards opening
Rechteckige Mannlochdeckel, Öffnung nach außen

Frame for concrete vats
Für Betonfässer

6010 CM

310 x 420 mm **AISI 304 - 316L**

- 1 frame - kragen
- 2 cover - deckler
- 3 gasket - dichtung
- 4 handwheel - hanggrift
- 5 arm - schulter
- 6 stirrup - bügel

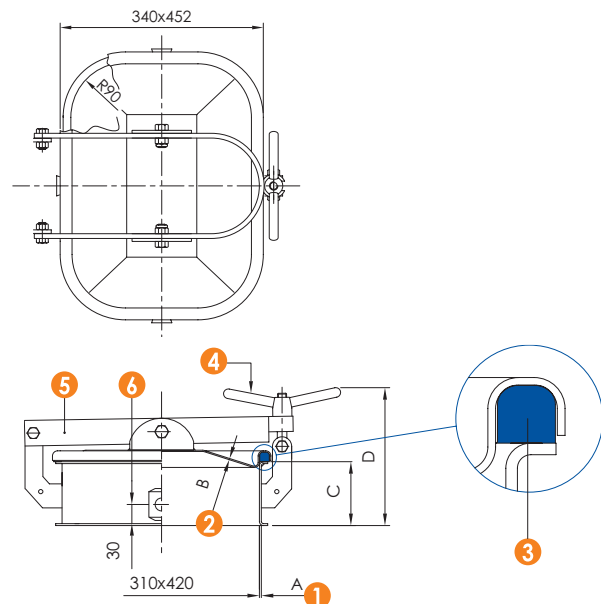

ART.	A	B	C	D	P. max bar
6010 CM	3	2	100	216	0,5



Rectangular manwaydoor outwards horizontal opening
Rechteckige Mannlochdeckel, waagerechte außen Öffnung

6010 E

310 x 420 mm **AISI 304 - 316L**

- ① frame - kragen
- ② cover - deckler
- ③ gasket - dichtung
- ④ handwheel - hanggriff
- ⑤ arm - schulter

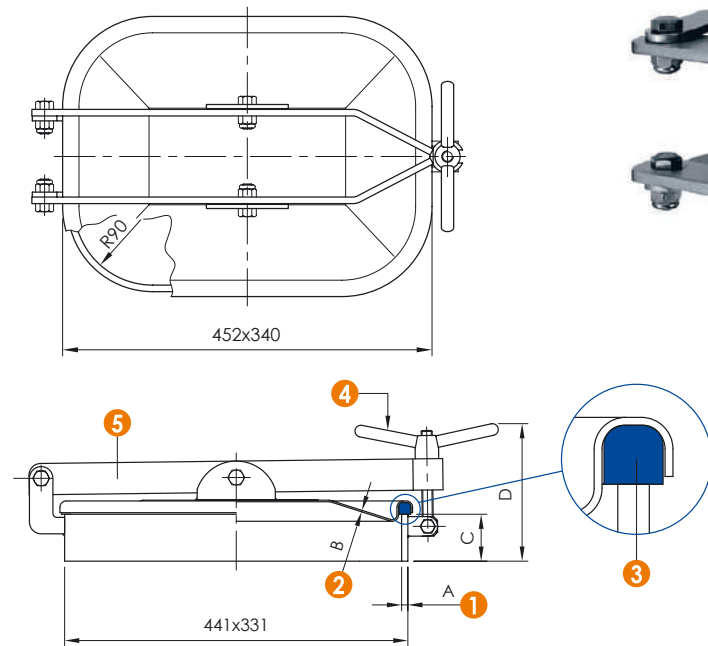

ART.	A	B	C	D	P. max bar
6010 E	8	2	80	200	0,5

Rectangular manwaydoor outwards opening
Rechteckige Mannlochdeckel, Öffnung nach außen

6010 G

310 x 420 mm **AISI 304 - 316L**

- ① frame - kragen
- ② cover - deckler
- ③ gasket - dichtung
- ④ handwheel - hanggriff
- ⑤ arm - schulter

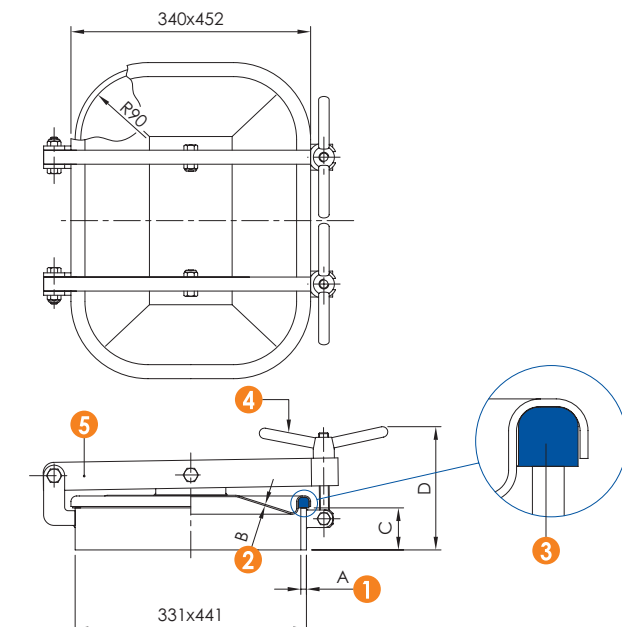

ART.	A	B	C	D	P. max bar
6010 G	10	2	60	200	0,7



Rectangular manwaydoor outwards opening
Rechteckige Mannlochdeckel, Öffnung nach außen

Frame for concrete vats
Für Betonfässer

6010 LCM

310 x 420 mm **AISI 304 - 316L**

- ① frame - kragen
- ② cover - deckler
- ③ gasket - dichtung
- ④ handwheel - hanggriff
- ⑤ arm - schulter
- ⑥ stirrup - bügel

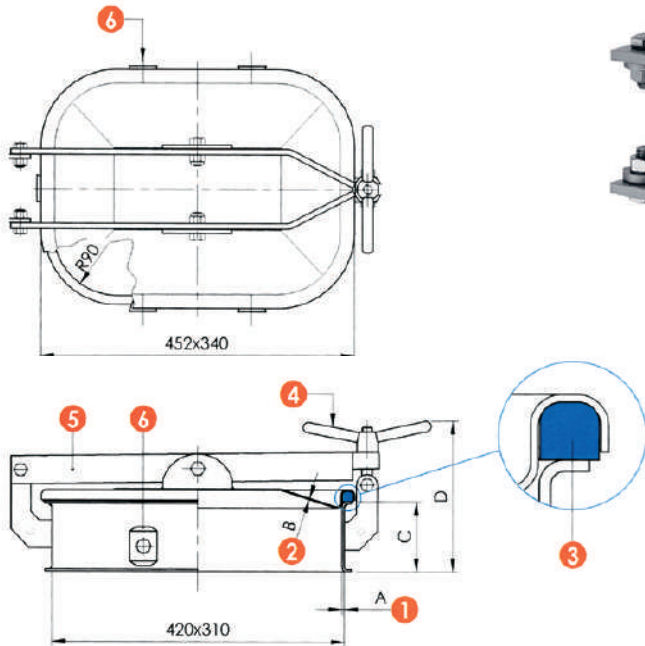

ART.	A	B	C	D	P. max bar
6010 LCM	3	2	100	196	0,5

Rectangular manwaydoor inwards opening
Rechteckige Mannlochdeckel, Öffnung nach innen

6011

310 x 420 mm **AISI 304 - 316L**

- ① frame - kragen
- ② cover - deckler
- ③ gasket - dichtung
- ④ handwheel - hanggriff
- ⑤ transom - riegel

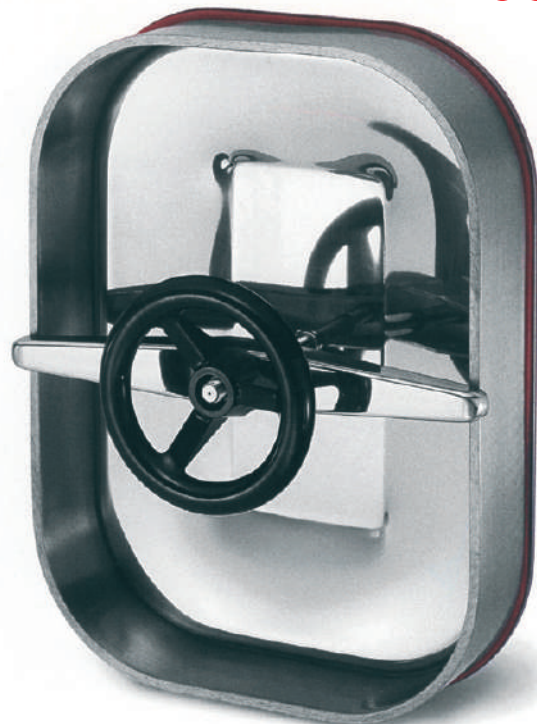
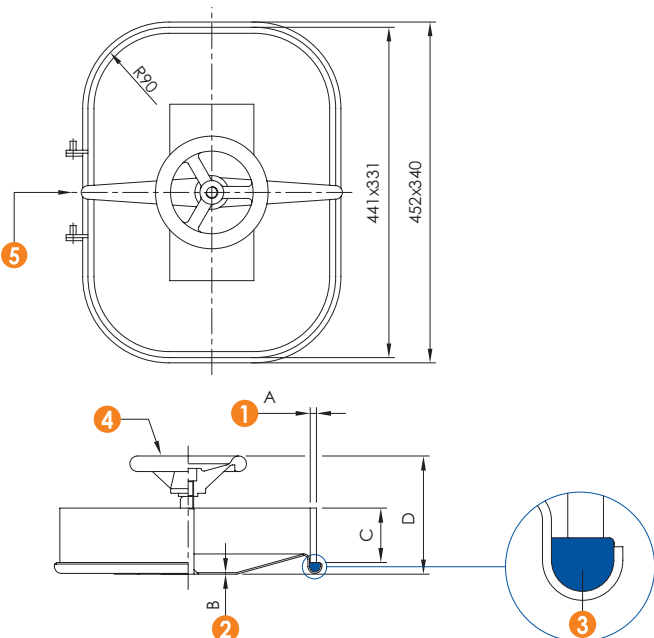

ART.	A	B	C	D	P. max bar
6011	8	2	80	150	1
6011 B - Cover only complete with acc. / Lediglich Deckel komplett mit Zubehör					



Rectangular manwaydoor inwards opening
Rechteckige Mannlochdeckel, Öffnung nach innen

Frame for concrete vats
Für Betonfässer

6011 CM

310 x 420 mm **AISI 304 - 316L**

- ① frame - kragen
- ② cover - deckler
- ③ gasket - dichtung
- ④ handwheel - hanggrift
- ⑤ transom - riegel
- ⑥ stirrup - bügel

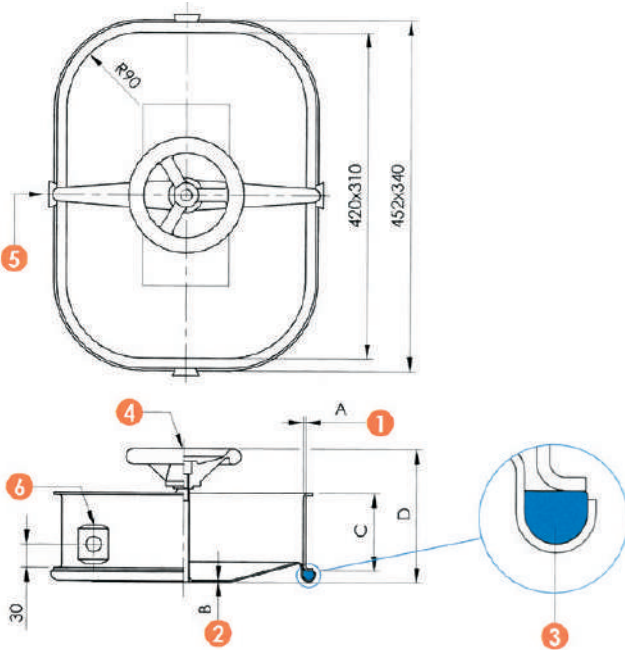

ART.	A	B	C	D	P. max bar
6011 CM	3	2	100	170	1

Rectangular manwaydoor outwards opening
Rechteckige Mannlochdeckel, Öffnung nach außen

410 x 530 mm **AISI 304 - 316L**

- ① frame - kragen
- ② cover - deckler
- ③ gasket - dichtung
- ④ handwheel - hanggrift
- ⑤ arm - schulter

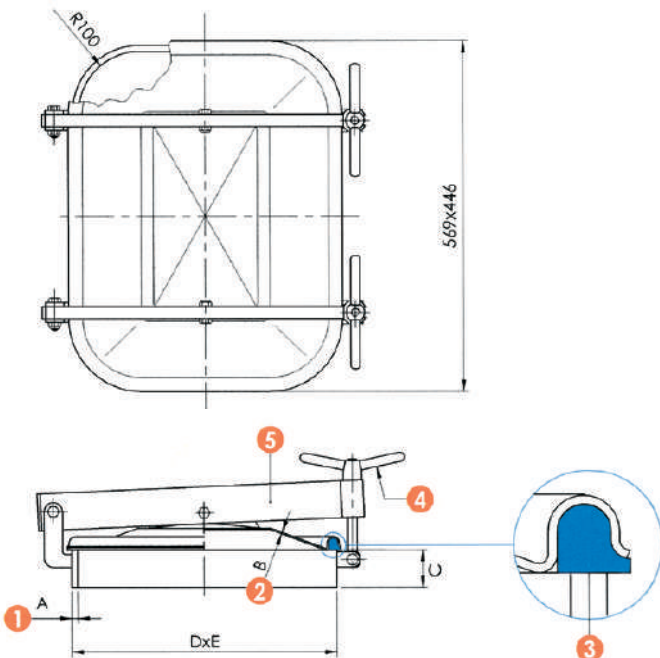

6012



ART.	A	B	C	D	E	P. max bar
6012	10	2,5	60	432	555	0,6
6012 A	10	2,5	100	432	555	0,6
6012 super	12	2,5	60	432	555	0,8
6012 A super	12	2,5	100	432	555	0,8

6012 B - Cover only complete with acc. / Lediglich Deckel komplett mit Zubehör



Rectangular manwaydoor outwards opening
Rechteckige Mannlochdeckel, Öffnung nach außen

6012 ECO

410 x 530 mm **AISI 304 - 316L**

- ① frame - kragen
- ② cover - deckler
- ③ gasket - dichtung
- ④ handwheel - hanggrift
- ⑤ arm - schulter

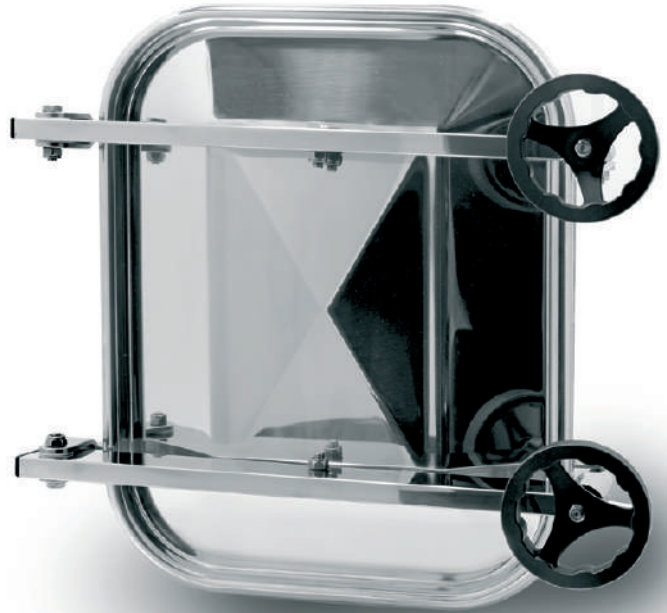
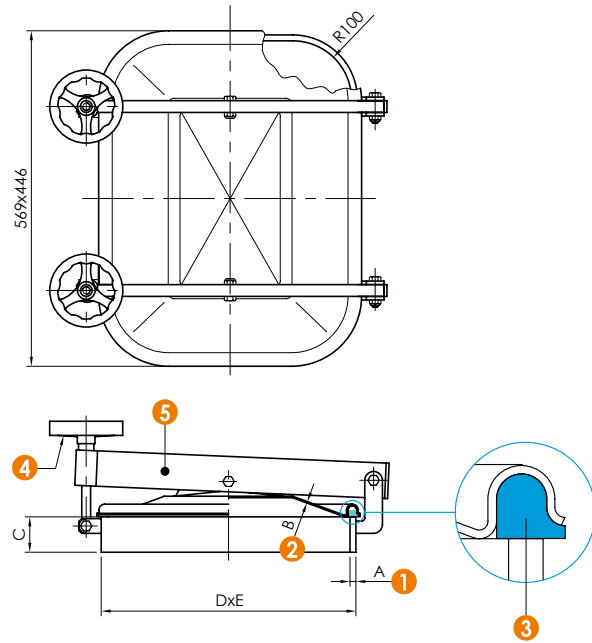

ART.	A	B	C	D	E	P. max bar
6012 ECO1	8	2	60	432	555	0,4
6012 ECO2	8	2	100	432	555	0,4

Rectangular manwaydoor outwards opening
Rechteckige Mannlochdeckel, Öffnung nach außen

Frame for concrete vats
Für Betonfässer

6012 CM

410 x 530 mm **AISI 304 - 316L**

- ① frame - kragen
- ② cover - deckler
- ③ gasket - dichtung
- ④ handwheel - hanggrift
- ⑤ arm - schulter
- ⑥ stirrup - bügel
- ⑦ protection - schutz - покрытие

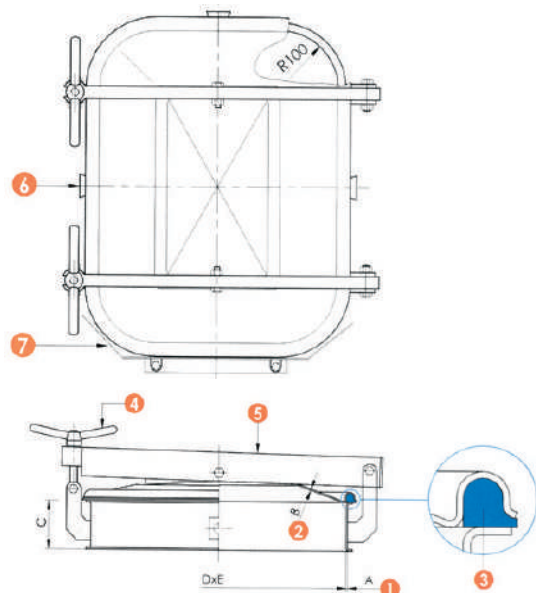

ART.	A	B	C	D	E	P. max bar
6012 CM	3	2	70	414	526	0,4



Rectangular manwaydoor inwards opening
Rechteckige Mannlochdeckel, Öffnung nach innen

410 x 530 mm **AISI 304 - 316L**

- ① frame - kragen
- ② cover - deckler
- ③ gasket - dichtung
- ④ handwheel - hanggrift
- ⑤ transom - riegel
- ⑥ arm - schulter

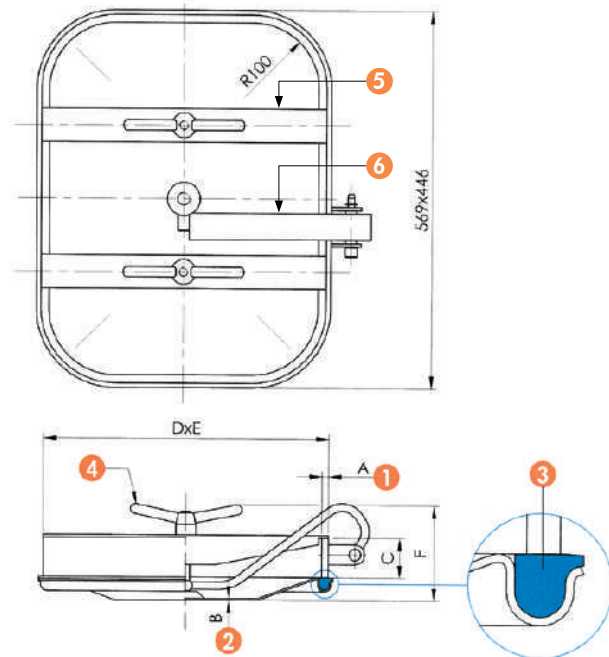

6012 E

ART.	A	B	C	D	E	F	P. max bar
6012 E	10	2,5	60	432	555	160	1,2
6012 E1	10	2,5	100	432	555	200	1,2
6012 E super	12	2,5	60	432	555	160	1,2
6012 E1 super	12	2,5	100	432	555	200	1,2

6012 F - Cover only complete with acc. / Lediglich Deckel komplett mit Zubehör

Rectangular manwaydoor outwards horizontal opening
Rechteckige Mannlochdeckel, waagerechte außen Öffnung

410 x 530 mm **AISI 304 - 316L**

- ① frame - kragen
- ② cover - deckler
- ③ gasket - dichtung
- ④ handwheel - hanggrift
- ⑤ arm - schulter

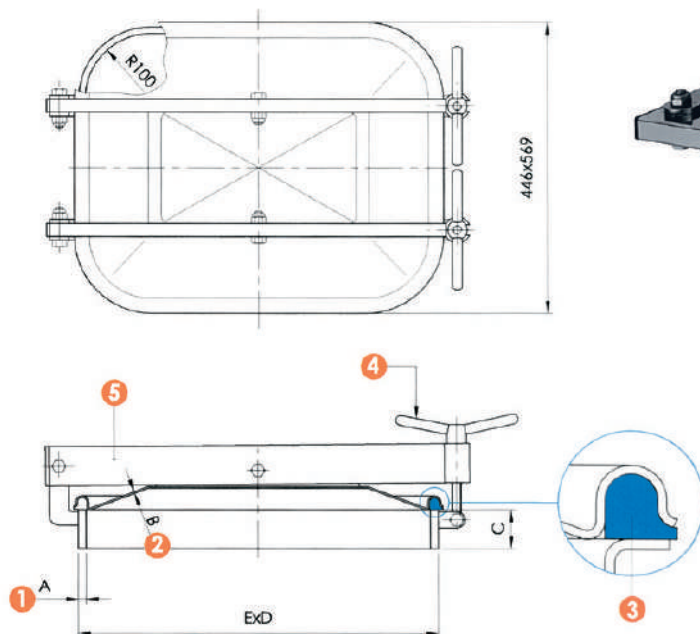

6013

ART.	A	B	C	D	E	P. max bar
6013	10	2,5	60	432	555	0,6
6013 A	10	2,5	100	432	555	0,6
6013 super	12	2,5	60	432	555	0,8
6013 A super	12	2,5	100	432	555	0,8

6013 B - Cover only complete with acc. / Lediglich Deckel komplett mit Zubehör



Rectangular manwaydoor outwards opening
Rechteckige Mannlochdeckel, Öffnung nach außen

Frame for concrete vats
Für Betonfässer

6013 CM

410 x 530 mm **AISI 304 - 316L**

- ① frame - kragen
- ② cover - deckler
- ③ gasket - dichtung
- ④ handwheel - hanggrift
- ⑤ arm - schulter

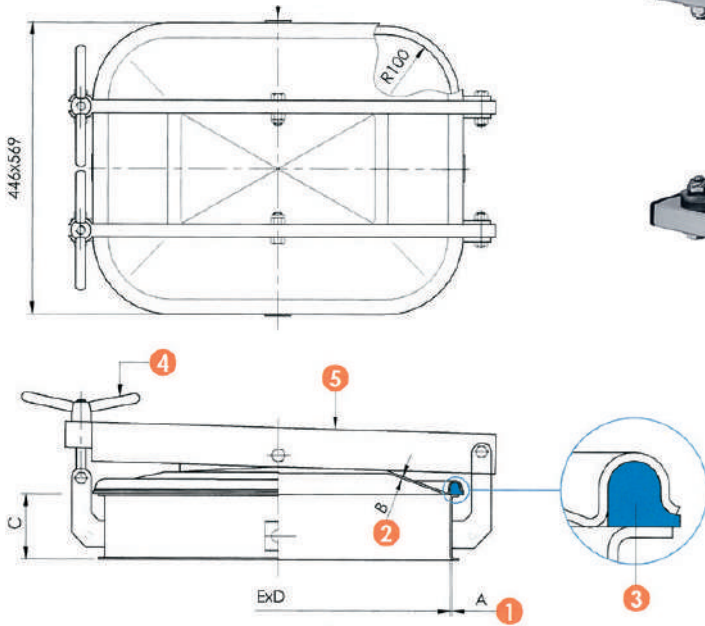

ART.	A	B	C	D	E	P. max bar
6013 CM	3	2	70	414	526	0,4

Rectangular manwaydoor outwards opening
Rechteckige Mannlochdeckel, Öffnung nach außen

6013 ECO

410 x 530 mm **AISI 304 - 316L**

- ① frame - kragen
- ② cover - deckler
- ③ gasket - dichtung
- ④ handwheel - hanggrift
- ⑤ arm - schulter

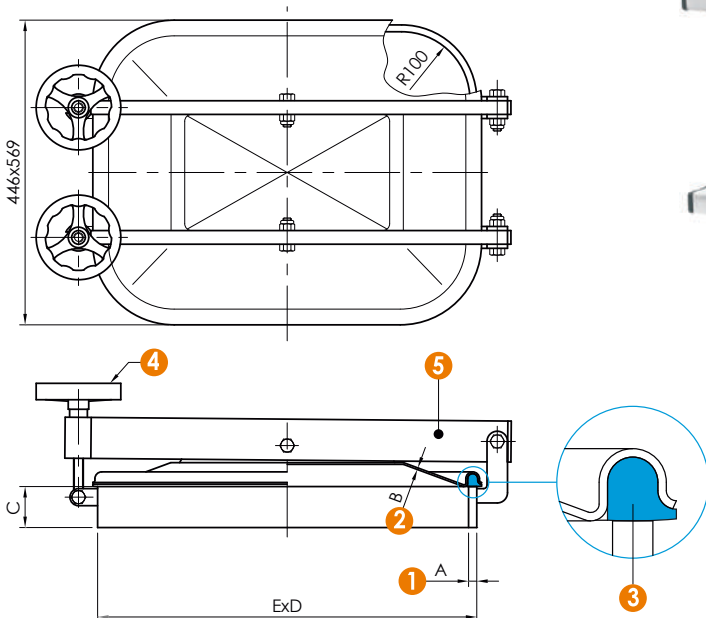

ART.	A	B	C	D	E	P. max bar
6013 ECO1	8	2	60	432	555	0,4
6013 ECO2	8	2	100	432	555	0,4



Rectangular manwaydoor outwards opening
Rechteckige Mannlochdeckel, Öffnung nach außen

6014

410 x 530 mm **AISI 304 - 316L**

- ① frame - kragen
- ② cover - deckler
- ③ gasket - dichtung
- ④ handwheel - hanggrift
- ⑤ reinforcement frame - bewehrungsrahmen
- ⑥ stirrup - bügel

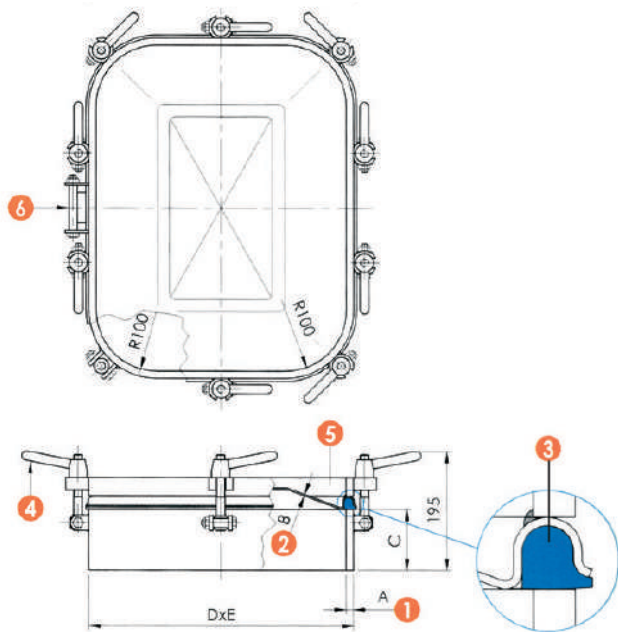

ART.	A	B	C	D	E	P. max bar
6014	12	2,5	100	432	555	4

Rectangular manwaydoor vertical guillotine opening
Rechteckige Mannlochdeckel, Öffnung nach Guillotine

6015

350 x 400 mm **AISI 304 - 316L**

- ① frame - kragen
- ② cover - deckler
- ③ gasket - dichtung
- ④ handwheel - hanggrift
- ⑤ transom - riegel

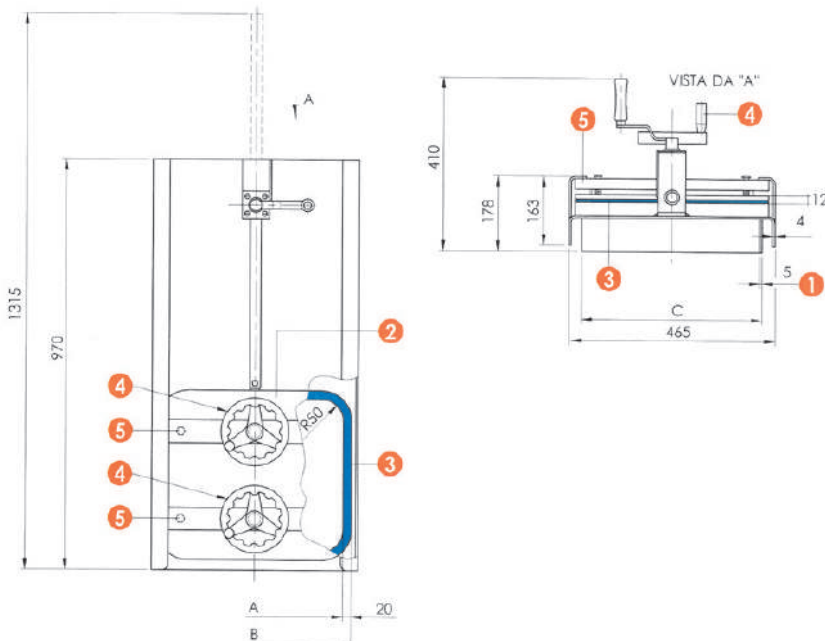

ART.	A	B	C	P. max bar
6015	415 x 360	455 x 400	425 x 370	1

6015 A - Manual or pneumatic opening Manuelle oder pneumatische Öffnung



Guillotine door with manual, pneumatic and electric opening
Guillotine-Tür mit manueller, pneumatischer und elektrischer Öffnung

6015 BE

412 x 535 mm **AISI 304 - 316L**

Access
Lichtweite

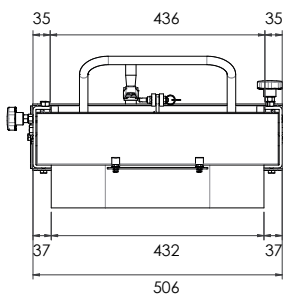
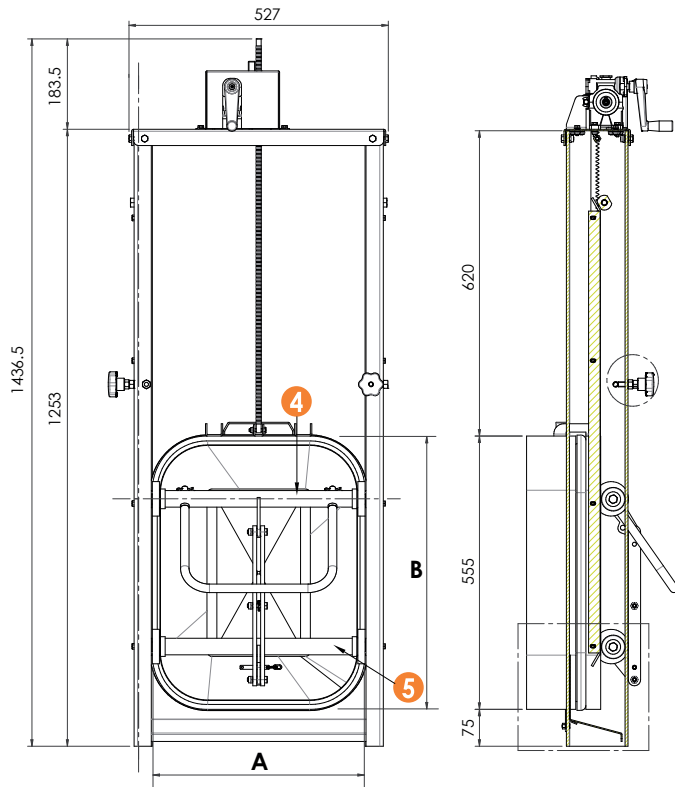
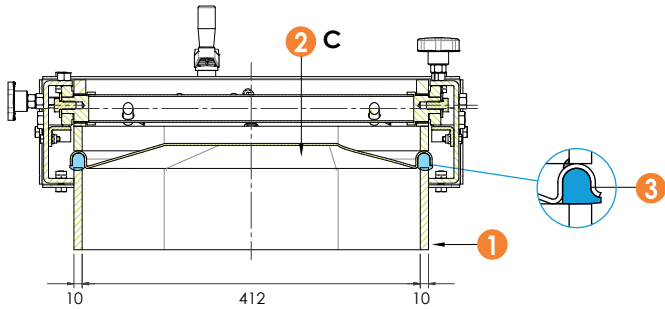

6015 BEP
Pneumatic opening
Pneumatische Öffnung

6015 BEM
Electric opening
Elektrische Öffnung



- ① frame - kragen
- ② cover - deckler
- ③ gasket - dichtung
- ④ handwheel - hanggrift
- ⑤ transom - riegel

ART.	A	B	C	P. max bar
6015 BE	432	555	2,5	1,5
6015 BEP	Pneumatic opening / Pneumatische Öffnung			
6015 BEE	Electric opening / Elektrische Öffnung			

Working temperature to -20°C / +50°C
Arbeitstemperatur bis -20°C / +50°C



Rectangular manwaydoor outwards opening
Rechteckige Mannlochdeckel, Öffnung nach außen

6015 C

445 x 730 mm **AISI 304 - 316 L**

- 1 frame - kragen
- 2 cover - deckler
- 3 gasket - dichtung
- 4 handwheel - hanggrift
- 5 transom - riegel

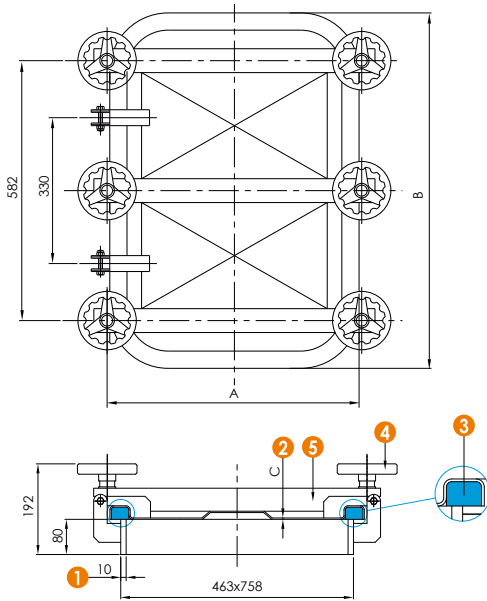

ART.	A	B	C	P. max bar
6015 C	490	780	2,0	1



Round manwaydoor
Runde Tür

Frame for concrete vats
Für Betonfässer

6016

Ø 420 mm AISI 304 - 316L

- 1 frame - kragen
- 2 cover - deckler
- 3 gasket - dichtung
- 4 handwheel - handgriff
- 5 arm - schulter

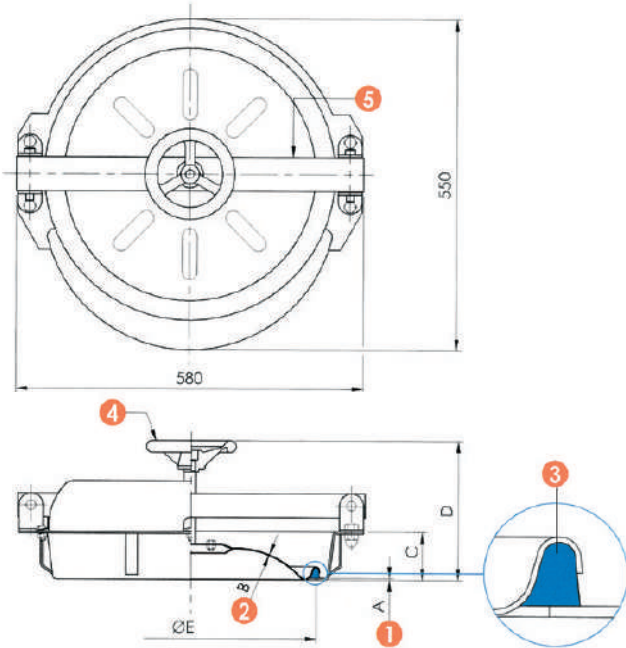

ART.	A	B	C	D	E	P _{max} bar
6016	3	2	80	230	420	0,4

Round manwaydoor outwards opening
Runde Tür, Öffnung nach außen

6017

Ø 420 mm AISI 304 - 316L

- 1 frame - kragen
- 2 cover - deckler
- 3 gasket - dichtung
- 4 handwheel - handgriff
- 5 arm - schulter

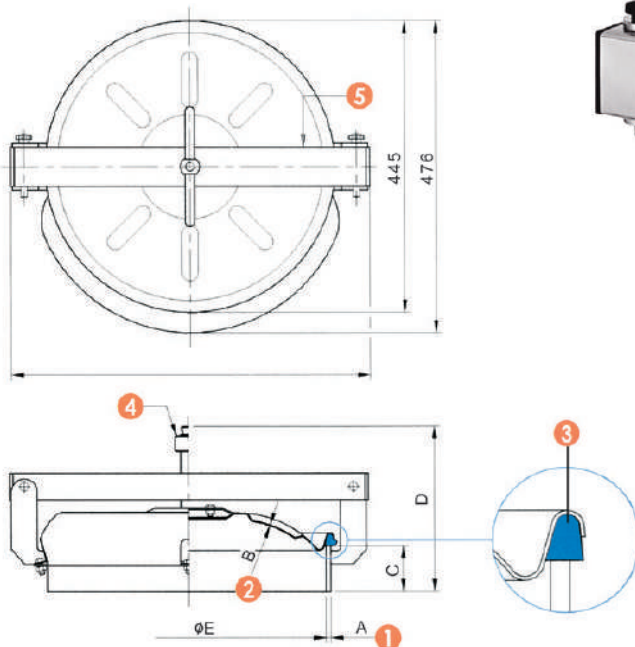

ART.	A	B	C	D	E	P _{max} bar
6017	8	2	80	150	420	0,5
6017 super	12	2	80	150	420	0,7



Round manwaydoor outwards opening for tankers
Runde Tür, Öffnung nach außen, für Tankwagen

6017 C

AISI 304/L - 316/L

- ① frame - kragen
- ② cover - deckel
- ③ gasket - dichtung
- ④ handwheel - hanggriff

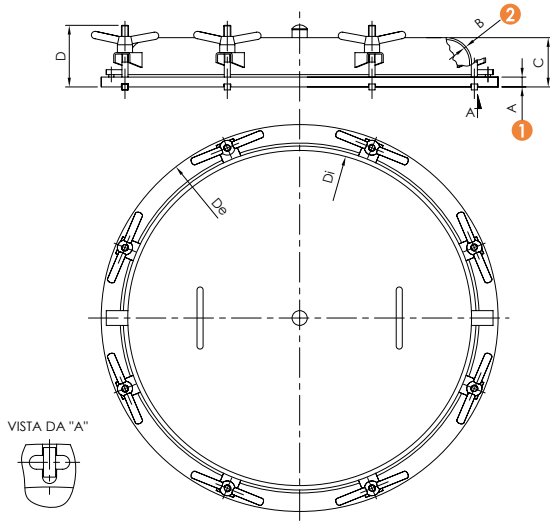
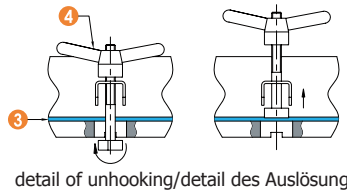

ART.	A	B	C	D	Di	De	P. max bar	Vacuum bar
6017C1	18	4	100	165	900	1016	2	-1
6017C2	18	4	100	165	680	785	4	-1

Manwaydoor with flange for fixing on wood
Mannlochtür mit Flanch für Holztank

6018 F

240 x 470 mm AISI 304 - 316L

- ① frame - kragen
- ② cover - deckler
- ③ gasket - dichtung
- ④ handwheel - hanggriff
- ⑤ transom - riegel

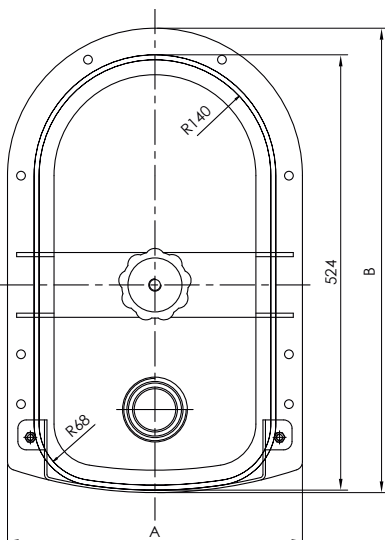
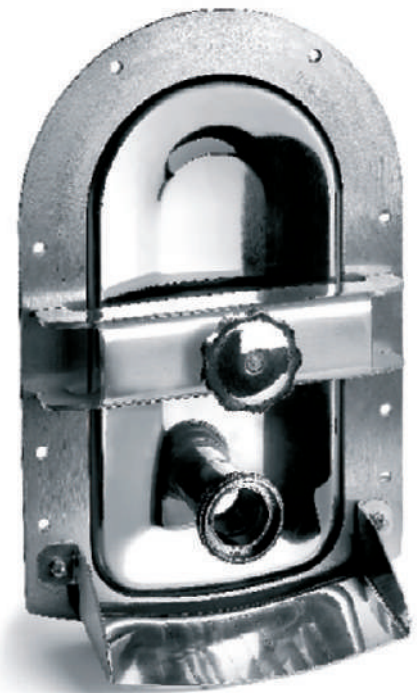
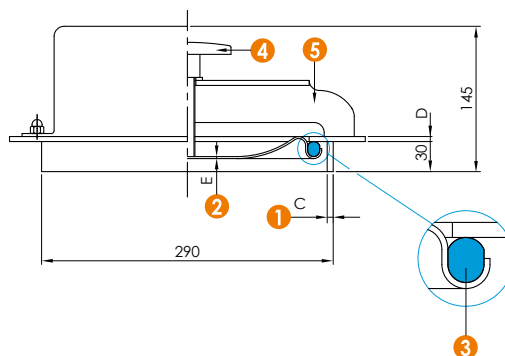

ART.	A	B	C	D	E	P. max bar
6018 F	355	560	6	5	2	0,5



Round manhole cover side-swing opening and back side opening
Runde Klaptür, Deckel seitlich schwenkbar

6022

AISI 304 - 316L

- ① frame - kragen
- ② cover - deckler
- ③ gasket - dichtung
- ④ handwheel - handgrift
- ⑤ arm - schulter

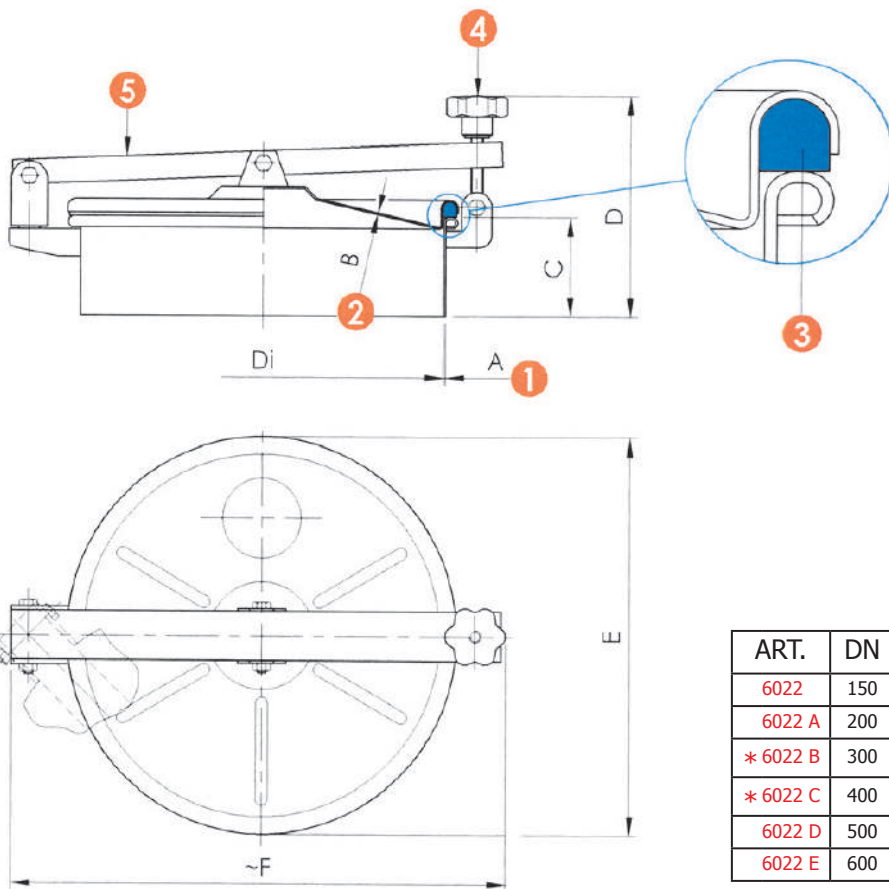

ART.	DN	Di	A	B	C	D	E	F	P. max bar
6022	150	145	2	1,5	80	164	174	259	0
6022 A	200	220	2	1,5	80	172	240	328	0
* 6022 B	300	299	2	1,5	80	180	322	420	0
* 6022 C	400	394	2	1,5	80	180	420	514	0
6022 D	500	499	2	1,5	80	202	526	620	0
6022 E	600	598	2	1,5	80	180	630	720	0

* Ribbing and valve seat for DN 300 and 400 only
Rippen und Ventilsitz (nur DN 300 und DN 400)



Round manhole cover back-side opening
Runde Klaptür, vertikale Öffnung

6022 ECO

AISI 304 - 316L

- 1 frame - kragen
- 2 cover - deckler
- 3 gasket - dichtung
- 4 handwheel - handgriff
- 5 arm - schulter
- 6 stirrup - bügel

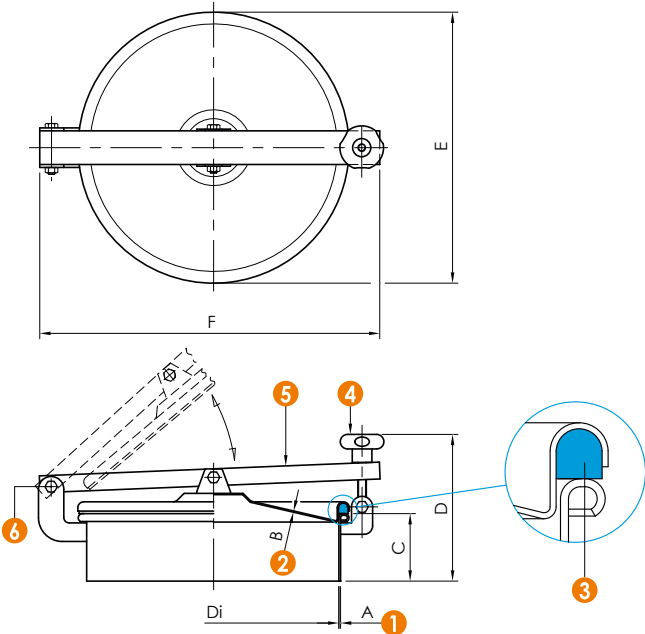

ART.	DN	Di	A	B	C	D	E	F	P. max bar
6022 A ECO	200	220	2	1,5	60	153	240	328	0
6022 B ECO	300	299	2	1,5	60	160	322	410	0
6022 C ECO	400	394	2	1,5	60	173	420	514	0
6022 D ECO	500	499	2	1,5	60	175	526	630	0
6022 E ECO	600	598	2	1,5	60	168	630	725	0

Round manwaydoor outwards opening for tankers
Runde Tür, Öffnung nach außen, für Tankwagen

6023

AISI 304 - 316L

- 1 frame - kragen
- 2 cover - deckler
- 3 gasket - dichtung
- 4 handwheel - handgriff

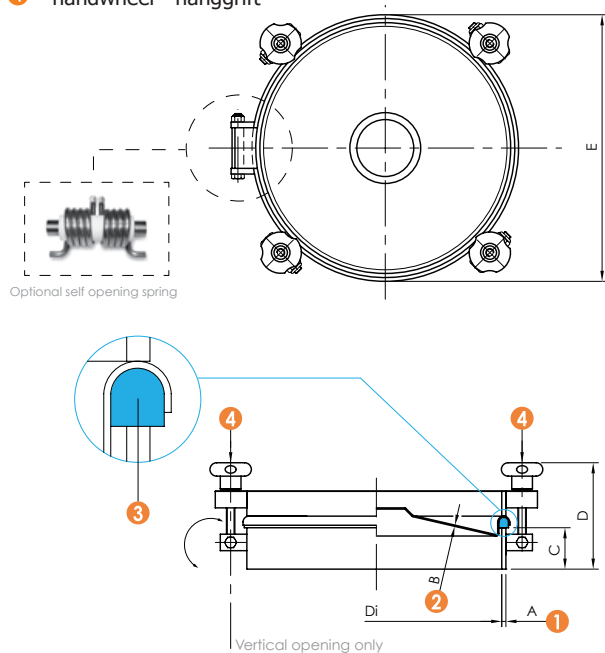

ART.	DN	Di	A	B	C	D	E	No 4	P. max bar	Vacuum bar
6023 A	200	220	8	1,5	60	136	240	3	3	-0,5
6023 B	300	300	8	1,5	60	136	321	4	3	-0,5
6023 C	400	398	8	1,5	60	137	420	5	1,5	-0,5
6023 D	500	500	8	1,5	60	136	526	6	1,5	-0,5
6023 E	600	600	8	1,5	60	144	630	7	1	-0,3



Round ovale manhole with peripheral closings
Ovale Mannloch mit Kunststoffgriffen

6023 F

AISI 304 - 316L

- ① frame - kragen
- ② cover - deckler
- ③ gasket - dichtung
- ④ handwheel - hanggrift

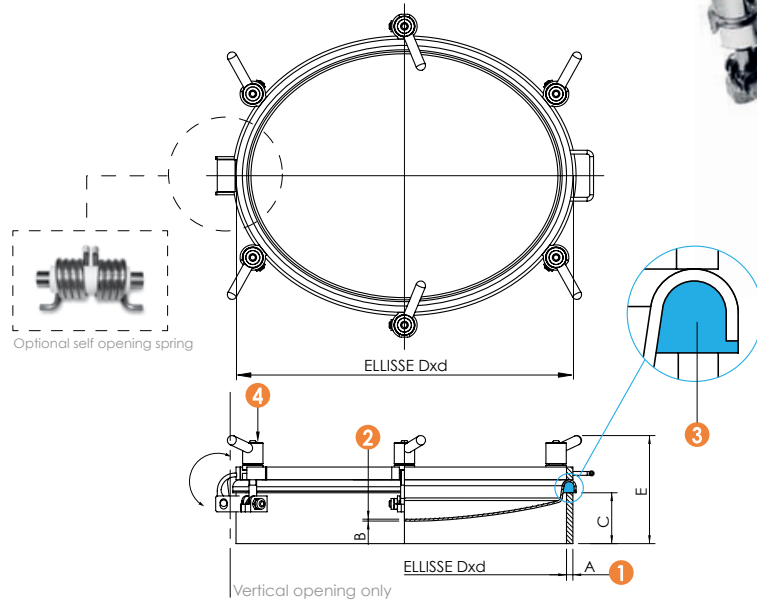

ART.	Dxd	A	B	C	E	N ^o ④	P. max bar	Vacuum bar
6023 F1	412x315	8	2,5	75	165	6	4	-1
6023 F2	510x410	10	3	80	170	8	3	-1

Round manhole with insulated lid
Runde Klapptür, mit isoliertem Deckel

6023 H

AISI 304 - 316L

- ① frame - kragen
- ② cover - deckler
- ③ gasket - dichtung
- ④ handwheel - hanggrift

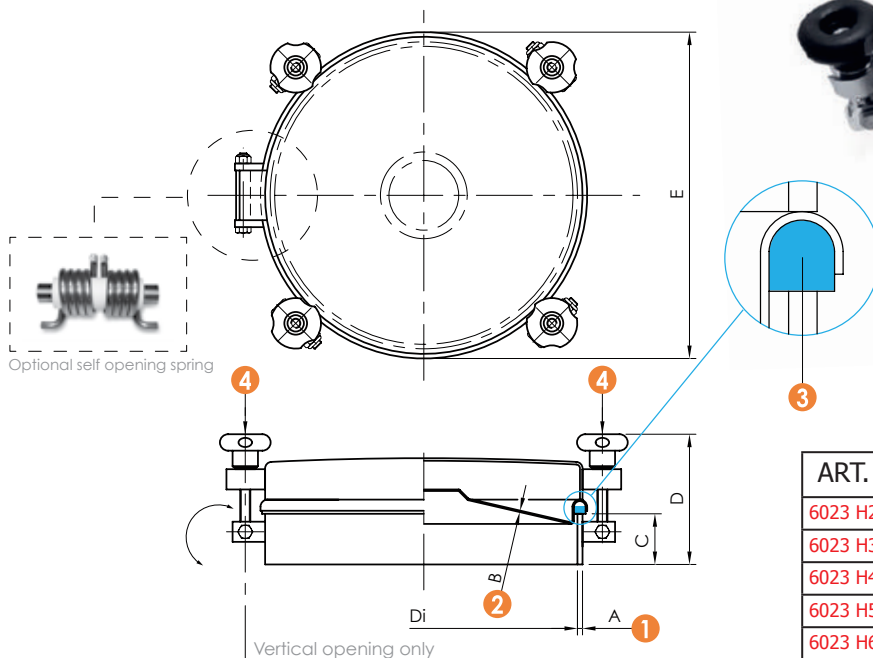

ART.	DN	Di	A	B	C	D	E	N ^o ④	P. max bar	Vacuum bar
6023 H2	200	220	8	1,5	60	135	240	3	3	-0,5
6023 H3	300	300	8	1,5	60	135	321	4	3	-0,5
6023 H4	400	398	8	1,5	60	136	420	5	1,5	-0,5
6023 H5	500	500	8	1,5	60	165	526	6	1,5	-0,5
6023 H6	600	600	8	1,5	60	165	630	7	1	-0,3



Round ovale manhole with insulated lid
Ovale Mannloch mit isoliertem Deckel
с изолированной крышкой

6023 H10/11

AISI 304 - 316L

- 1 frame - kragen
- 2 cover - deckler
- 3 gasket - dichtung
- 4 handwheel - hanggrift
- 5 insulation - isolierung

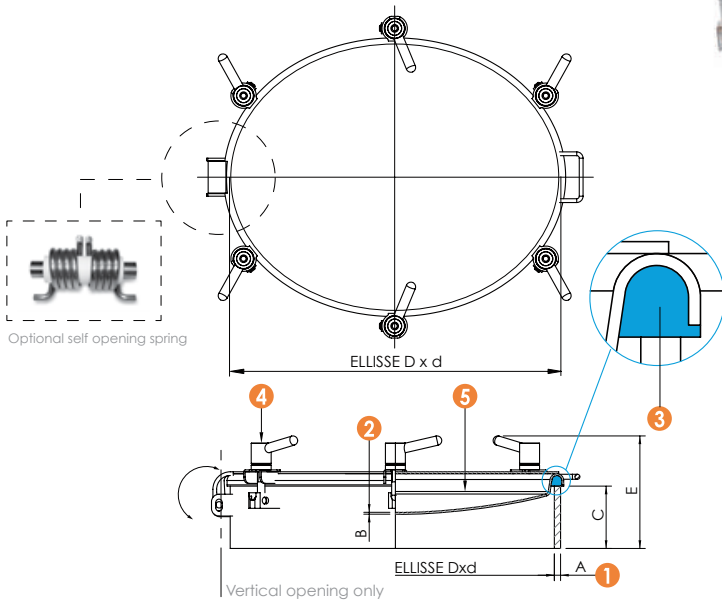

ART.	Dxd	A	B	C	E	P. max bar	Vacuum bar
6023 H10	412x315	8	2,5	75	165	4	-1
6023 H11	510x410	10	3	85	170	3	-1

Round manhole with peripheral closings
Runde Klapptür, mit Spannvorrichtungen

6024

50 x 5

AISI 304 - 316L

- 1 frame - kragen
- 2 cover - deckler
- 3 gasket - dichtung
- 4 handwheel - hanggrift

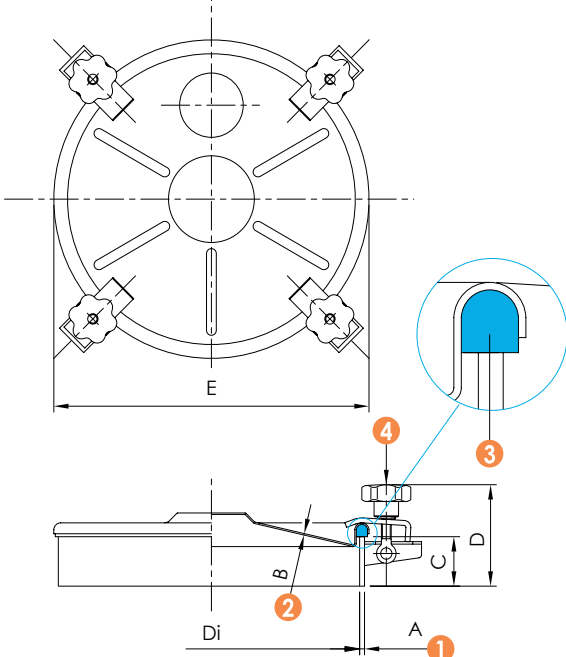

ART.	DN	Di	A	B	C	D	E	Nº 4	P. max bar	Vacuum bar
6024 A	200	223	5	1,5	50	103	300	3	0,1	-0,5
* 6024 B	300	304	5	1,5	50	103	381	3	0,1	-0,5
* 6024 C	400	398	5	1,5	50	103	420	4	0,1	-0,5
6024 D	500	500	5	1,5	50	111	526	5	0,05	-0,5
6024 E	600	600	5	1,5	50	111	630	6	0,05	-0,3

6025 - Cover only complete with acc. / Lediglich Deckel komplett mit Zubehör

* Ribbing and valve seat for DN 300 and 400 only
Rippen und Ventilsitz (nur DN 300 und DN 400)



Round manhole with peripheral closings
Runde Klapptür, mit Flachrahmen und Spannvorrichtungen

6025 L

AISI 304 - 316L

- ① frame - krágen
- ② cover - deckler
- ③ gasket - dichtung
- ④ peripheral closing - spannvorrichtung

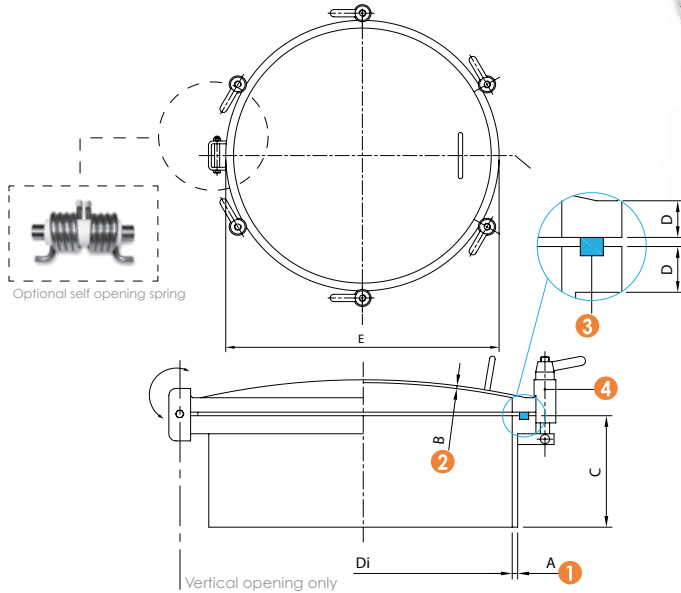

Available with PVC handle

ART.	DN	Di	A	B	C	D	E	Nº ④	P. max bar	Vacuum bar
6025 L15	150	150	4	2	120	20	190	3	4	-1
6025 L2	200	200	4	3	120	20	240	4	4	-1
6025 L3	300	300	6	4	120	20	340	4	4	-1
6025 L35	350	350	6	4	120	20	390	4	4	-1
6025 L4	400	400	6	4	120	20	440	6	4	-1
6025 L45	450	450	6	4	120	20	490	6	3	-1
6025 L5	500	500	6	4	120	20	540	6	3	-1
6025 L6	600	600	6	5	125	25	650	6	2	-1

Round manhole with peripheral closings
Runde Klapptür, mit Flachrahmen und Spannvorrichtungen

6025 P (type A)

AISI 304 - 316L

- ① frame - krágen
- ② cover - deckler
- ③ gasket - dichtung
- ④ peripheral closing - spannvorrichtung
- ⑤ sight glass - schauglas

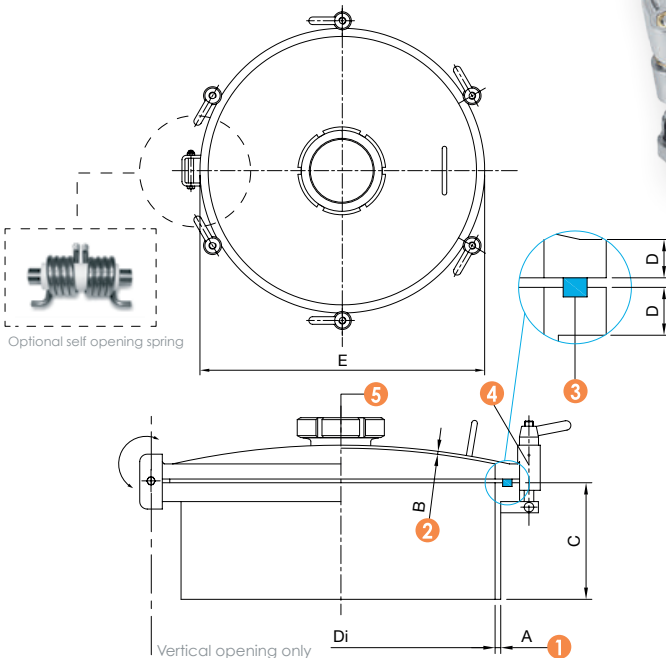

6025 P (type B)



Available with PVC handle (ECO)

ART.	DN	Di	A	B	C	D	E	Nº ④	P. max bar	Vacuum bar
6025 P15	150	150	4	2	120	20	190	3	4	-1
6025 P2	200	200	4	3	120	20	240	4	4	-1
6025 P3	300	300	6	4	120	20	340	4	4	-1
6025 P35	350	350	6	4	120	20	390	4	4	-1
6025 P4	400	400	6	4	120	20	440	6	4	-1
6025 P45	450	450	6	4	120	20	490	6	3	-1
6025 P5	500	500	6	4	120	20	540	6	3	-1
6025 P6	600	600	6	5	125	25	650	6	2	-1



Round manhole cover back-side opening
Runde Kapptür, vertikale Öffnung

6025 RM

AISI 304L - 316L

- ① frame - kragen
- ② cover - deckler
- ③ gasket - dichtung
- ④ handwheel - handgriff

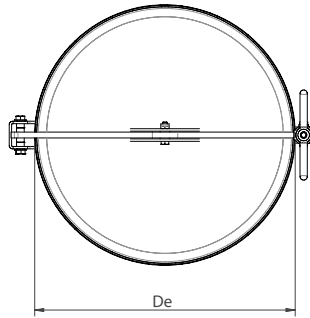
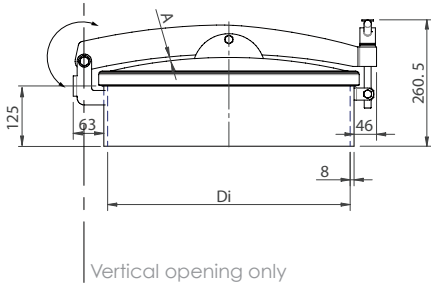

ART.	DN	Di	De	A	P. max bar	Vacuum bar
6025 RM3	300	305	342	4	0,15	-1
6025 RM4	400	400	437	4	0,1	-1
6025 RM5	500	500	537	4	0,1	-1
6025 RM6	600	600	637	6	0,05	-1

Round manhole with peripheral closings
Runde Druckverschlüsse mit Flachrahmen und Spannvorrichtungen

6025 RP

AISI 304 L - 316 L

- ① frame - kragen (ST/MR)
- ② cover - deckler (MR)
- ③ gasket - dichtung
- ④ handwheel - handgriff

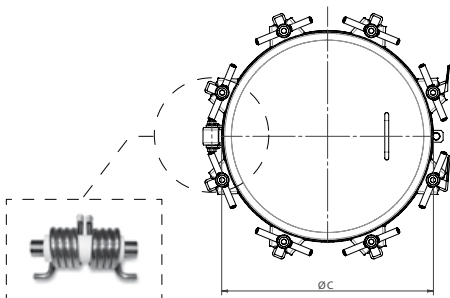
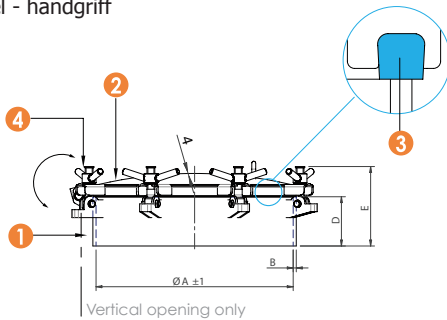

ART.	DN	ØA	B	ØC	D	E	kg	Nr. Handwheel	Temp. °C	P. max bar	Vacuum bar
6025 RP3	300	305	8	342	125	201	20	3	-20/+200	2,7	-1
							22	4	-20/+200	4,0	-1
6025 RP4	400	400	8	437	125	201	28	4	-20/+200	1,5	-1
							30	6	-20/+200	3,0	-1
6025 RP5	500	500	8	537	125	201	32	8	-20/+200	4,0	-1
							34	4	-20/+200	1,5	-1
6025 RP6	600	600	8	637	125	201	37	6	-20/+200	2,7	-1
							39	8	-20/+200	4,0	-1
6025 RP6	600	600	8	637	125	201	44	6	-20/+200	1,0	-1
							46	8	-20/+200	2,5	-1
							48	10	-20/+200	3,0	-1



Round manhole with full sight glass and peripheral closings
 Druck-Glassverschlüsse mit Handgriffen

6025 V

AISI 316L

- ① frame - kragen
- ② cover - deckler
- ③ glass - glas - стекло
- ④ gasket - dichtung
- ⑤ gasket - dichtung
- ⑥ gasket - dichtung
- ⑦ peripheral closing - spannvorrichtung

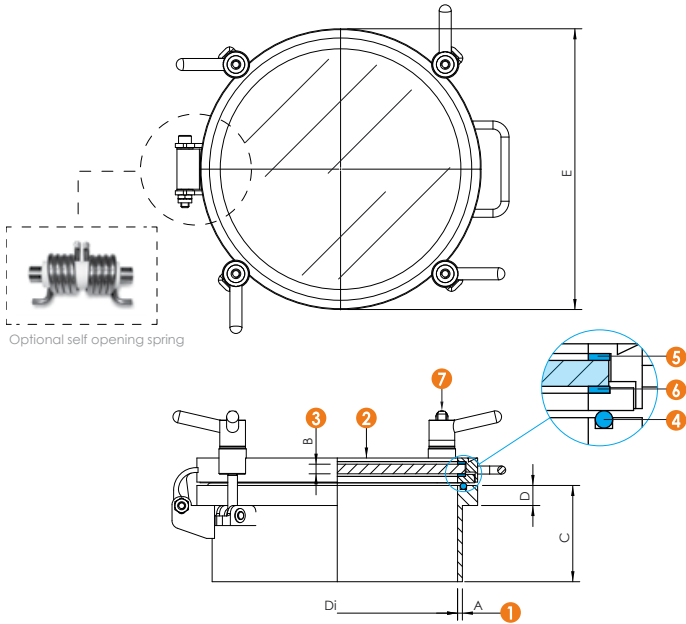

ART.	DN	Di	A	B	C	D	E	N ^o ⑦	P. max bar	Vacuum bar
6025 V2	200	200	6	12	120	25	250	4	3	-1
6025 V3	300	300	6	12	120	25	350	4	3	-1
6025 V4	400	400	6	12	120	25	450	6	3	-1
6025 V5	500	500	6	12	120	25	550	6	1,5	-1
6025 V6	600	600	6	15	120	25	650	6	1	-1

Round manhole with central closure
 Runde Klapptür, Schleisst in der Mitte

6026 N

AISI 304 - 316L

- ① frame - kragen
- ② cover - deckler
- ③ gasket - dichtung
- ④ handwheel - handgriff
- ⑤ arm - schulter

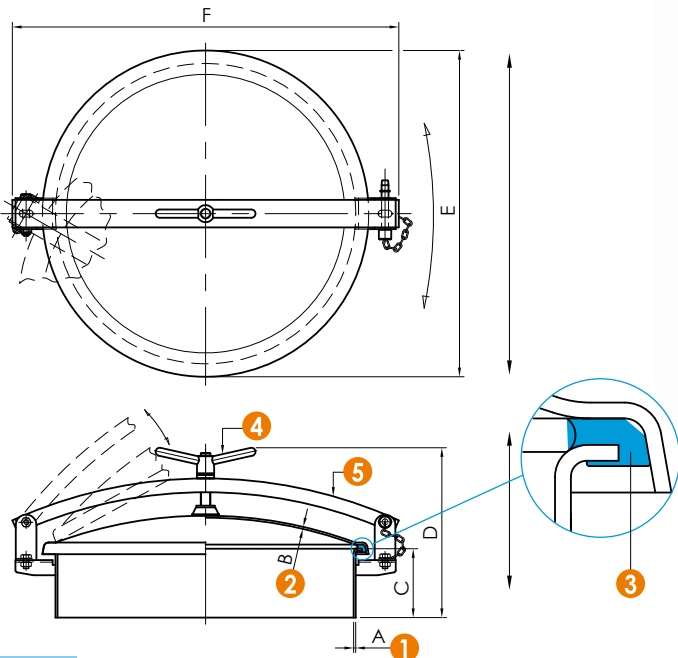

ART.	DN	Di	A	B	C	D	E	F	P. max bar	Vacuum bar
6026 N-1	400	400	3	2	100	250	474	515	0,01	-0,7
6026 N-2	500	500	3	2	100	250	544	625	0,01	-0,5
6026 N-3	600	600	3	2	100	250	640	715	0,01	-0,5



Round manhole cover side-swing opening and back-side opening
Runde Klapptür, Deckel seitlich schwenkbar

6027 A

AISI 304 - 316L

- 1 frame - kragen
- 2 cover - deckler
- 3 gasket - dichtung
- 4 handwheel - hanggrift
- 5 arm - schulter
- 6 stirrup - bügel

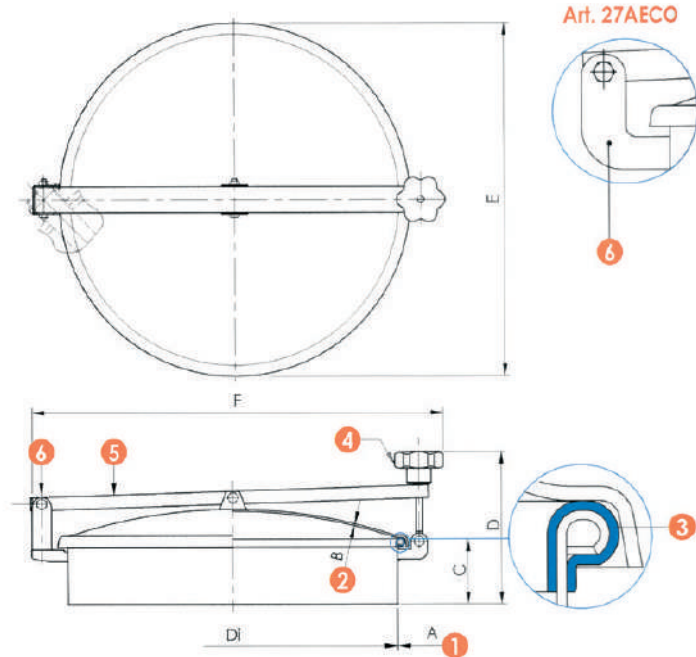

ART.	DN	Di	A	B	C	D	E	F	P _{max} bar
6027 A2	200	200	2	2	80	172	245	315	0
6027 A3	300	300	2	2	80	190	345	415	0
6027 A4	400	400	2	2	80	190	439	515	0
6027 A45	450	450	2	2	80	224	491	565	0
6027 A5	500	500	2	2	80	180	544	625	0
6027 A6	600	600	2	2	80	202	640	715	0

6027 A9 - Cover only complete with acc. / Lediglich Deckel komplett mit Zubehör

Round manhole
Runde Klapptür

6027 A ECO

AISI 304 - 316L

- 1 frame - kragen
- 2 cover - deckler
- 3 gasket - dichtung
- 4 handwheel - hanggrift
- 5 arm - schulter
- 6 stirrup - bügel

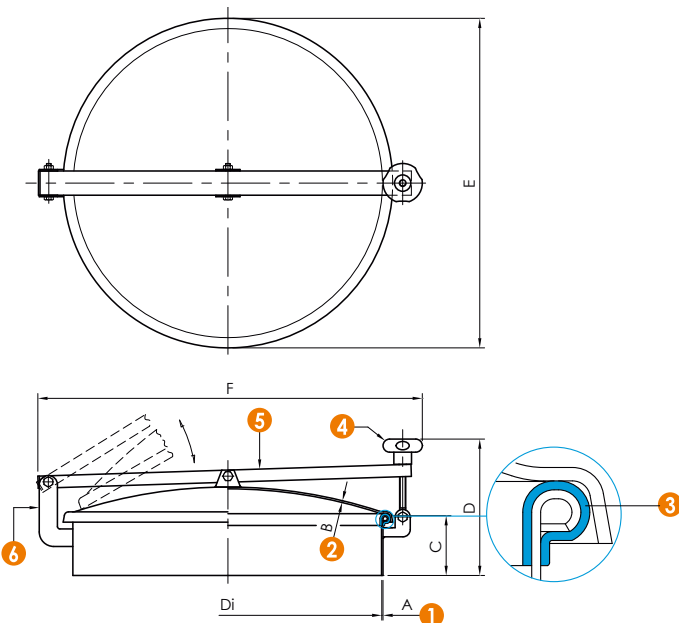

ART.	DN	Di	A	B	C	D	E	F	P _{max} bar
6027 A2 ECO	200	200	2	2	60	180	245	315	0
6027 A3 ECO	300	300	2	2	60	192	345	415	0
6027 A4 ECO	400	400	2	2	60	189	438	515	0
6027 A5 ECO	500	500	2	2	60	190	544	620	0
6027 A6 ECO	600	598	2	2	60	219	640	715	0

6027 A9 ECO - Cover only complete with acc. / Lediglich Deckel komplett mit Zubehör



Round manhole cover side-swing opening and back-side opening
Runde Klapptür, Deckel seitlich schwenkbar

6027 E

AISI 304 - 316L

- 1 frame - kragen
- 2 cover - deckler
- 3 gasket - dichtung
- 4 handwheel - handgrift
- 5 arm - schulter

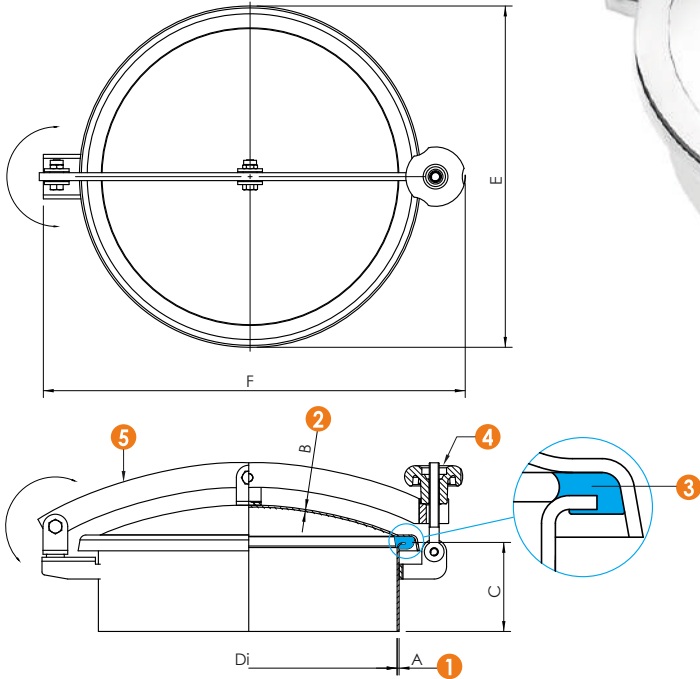

ART.	DN	Di	A	B	C	E	F	P. max bar
6027 E2	200	200	2	2	90	245	327	0,01
6027 E3	300	300	2	2	90	355	427	0,01
6027 E4	400	400	2	2	90	435	527	0,01
6027 E5	500	499	2	2	90	544	626	0,01
6027 E6	600	598	2	2	90	640	725	0,01

Round manhole cover side-swing opening and back-side opening
Runde Klapptür, Deckel seitlich schwenkbar

6027 L

AISI 304 - 316L

- 1 frame - kragen
- 2 cover - deckler
- 3 gasket - dichtung
- 4 handwheel - handgrift
- 5 arm - schulter

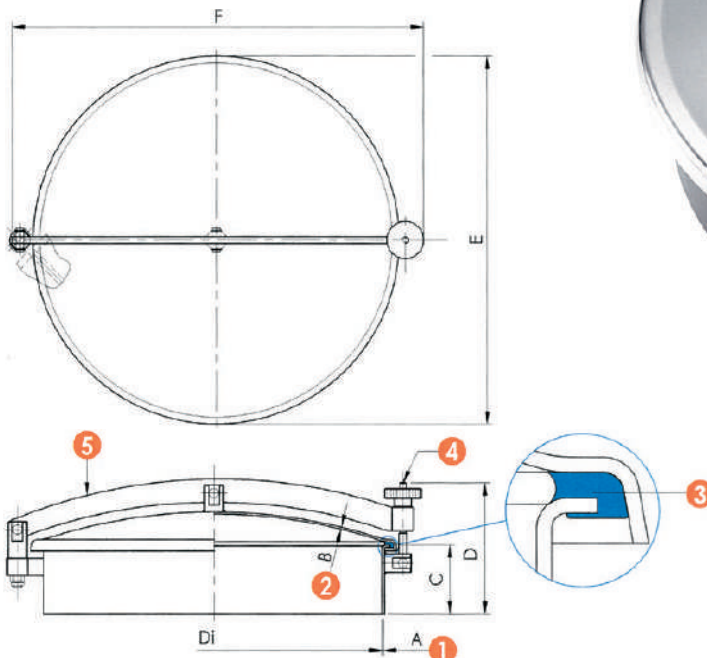

ART.	DN	Di	A	B	C	D	E	F	P. max bar
6027 L2	200	200	3	3	103	203	245	325	0,05
6027 L3	300	300	3	3	103	205	345	425	0,05
6027 L4	430	430	3	3	103	205	474	555	0,05
6027 L45	450	444	3	2,5	103	200	490	570	0,05
6027 L5	500	500	3	3	103	209	544	625	0,04
6027 L6	600	600	3	3	103	205	640	725	0,04



Round manhole with full sight glass
Runde Mannloch, Drucklos

6027 VS

AISI 316L

- ① frame - kragen
- ② glass - glas
- ③ gasket - dichtung
- ④ handwheel - handgrift

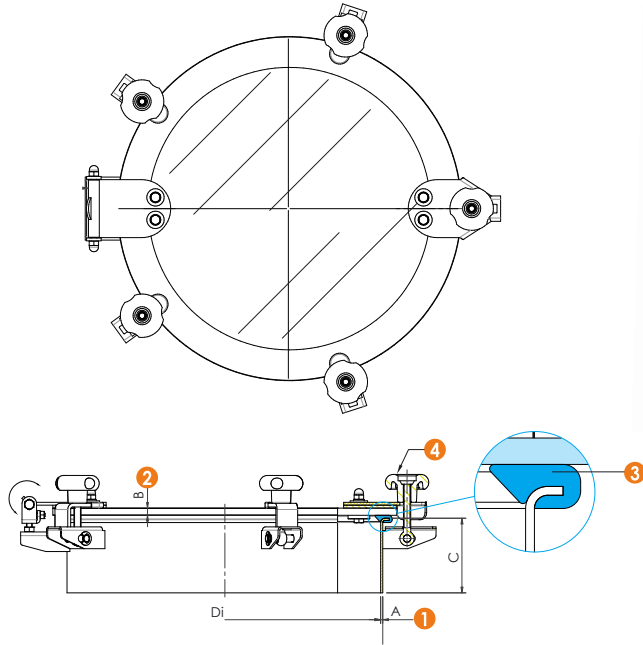

ART.	DN	Di	A	B	C	P. max bar
6027 V4	430	430	3	10	103	0,01
6027 V5	500	500	3	10	103	0,01
6027 V6	600	600	3	10	103	0,01

Round manhole with pheripheral closing
Runde Klapptür, mit Spannvorrichtungen

6028 A

AISI 304 - 316L

- ① frame - kragen
- ② cover - deckler
- ③ gasket - dichtung
- ④ peripheral closings - spannvorrichtung
- ⑤ arm - schulter

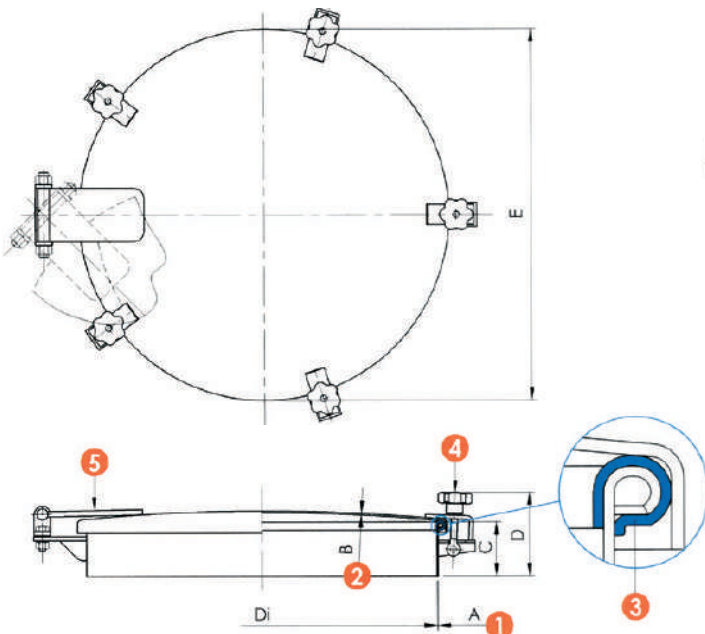

ART.	DN	Di	A	B	C	D	E	No	P. max bar	Vacuum bar
6028 A2	200	200	2	2	80	125	245	3	0,1	-0,5
6028 A3	300	300	2	2	80	125	345	4	0,1	-0,5
6028 A4	400	400	2	2	80	125	439	4	0,1	-0,5
6028 A5	500	500	2	2	80	125	544	5	0,05	-0,5
6028 A6	600	598	2	2	80	125	640	6	0,06	-0,3



Big sizes round manhole with peripheral closings
 Groß Durchmesser Runde Klapptür mit Spannvorrichtungen

6028 C

AISI 304 - 316L

- ① frame - kragen
- ② cover - deckler
- ③ gasket - dichtung
- ④ peripheral closings - spannvorrichtung
- ⑤ arm - schulter

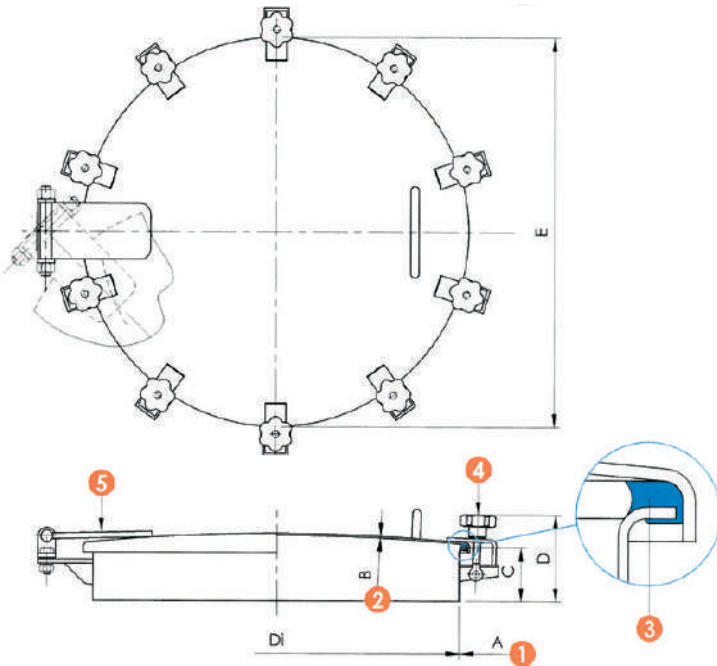

ART.	DN	Di	A	B	C	D	E	N ^o	P _{max} bar
6028 C7	750	740	3	1,2	100	145	785	7	0,01
6028 C9	900	888	3	1,5	100	155	950	8	0,01
6028 C4	1200	1200	3	2	100	145	1255	12	0,01
6028 C5	1400	1400	3	2	100	145	1455	14	0,01

Round manhole with double arm
 Runde Klapptür, mit Doppel Arm

6028 E

AISI 304 - 316L

- ① frame - kragen
- ② cover - deckler
- ③ gasket - dichtung
- ④ handwheel - hanggrift
- ⑤ arm - schulter

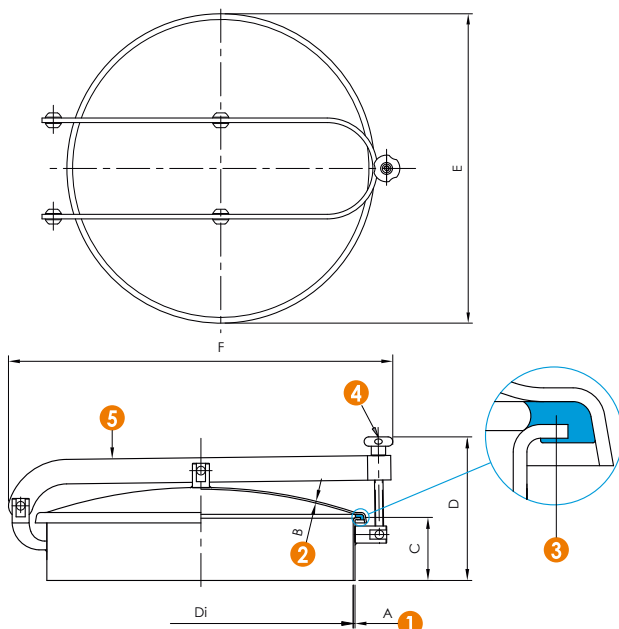

ART.	DN	Di	A	B	C	D	E	F	P _{max} bar
6028 E	400	430	3	3	103	255	474	625	0,01
6028 E3	450	444	3	2,5	103	250	490	675	0,01
6028 E1	500	500	3	3	103	250	544	695	0,01
6028 E2	600	600	3	3	103	239	640	699	0,01



Round manhole with peripheral closings
Runde Klapptür mit Kunststoffgriffen

6028 F

AISI 304 - 316L

- 1 - frame - kragen
- 2 - cover - deckler
- 3 - gasket - dichtung
- 4 - handwheel - hanggrift
- 5 - arm - arm

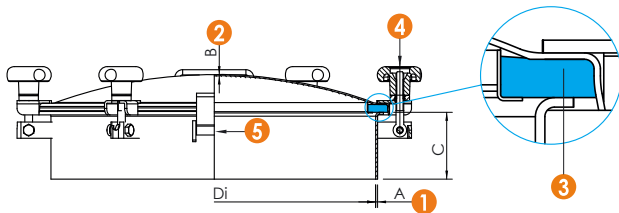
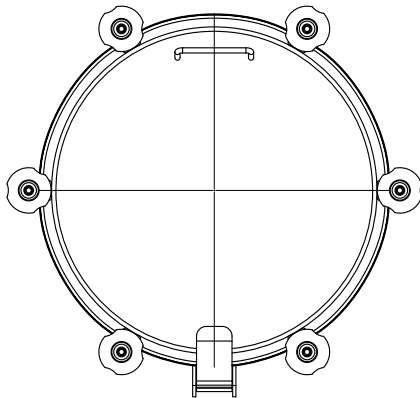

ART.	DN	Di	A	B	C	D	P. max bar	Vacuum bar
6028F4	430	430	3	3	103	474	0,5	-0,5
6028F5	500	500	3	3	103	544	0,4	-0,5
6028F6	600	600	3	3	103	640	0,3	-0,3

Round manhole
Runde Klapptür

6029 A

AISI 304 - 316L

- 1 frame - kragen
- 2 cover - deckler
- 3 gasket - dichtung

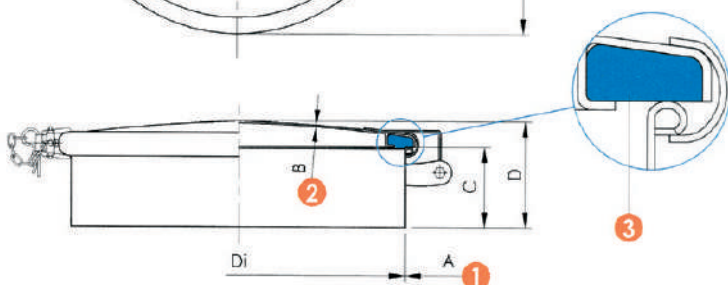
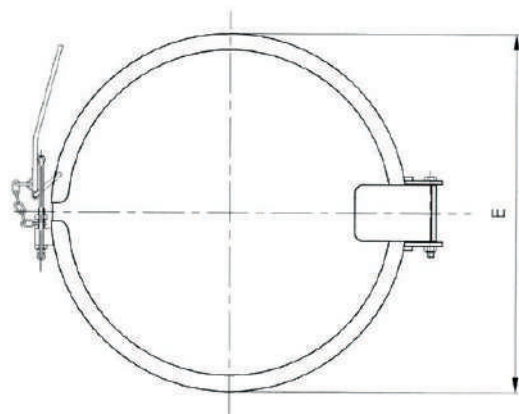

ART.	DN	Di	A	B	C	D	E	P. max bar	Vacuum bar
6029A2	200	200	2	2	100	130	245	2	-0,5
6029A3	300	299	2	2	100	130	345	2	-0,5
6029A4	400	398	2	2	100	130	445	1,5	-0,5
6029A5	500	498	2	2	100	130	544	0,8	-0,5
6029A6	600	598	2	2	100	130	640	0,5	-0,3



Big sizes round manhole
Groß Durchmesser Runde Klapptür

6029 P

AISI 304 - 316L

- ① frame - kragen
- ② cover - deckler
- ③ gasket - dichtung
- ④ stirrup - bügel

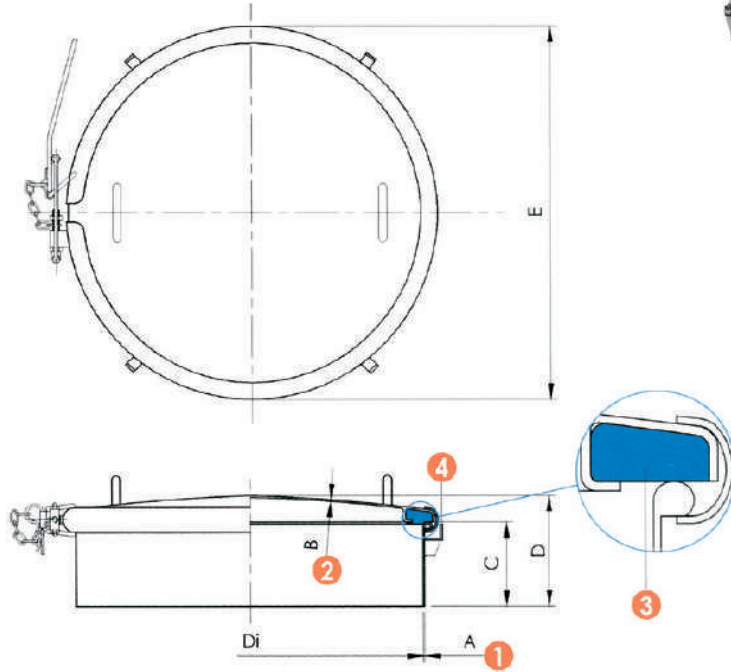

ART.	DN	Di	A	B	C	D	E	P _{bar} max
6029PA	800	806	3	2	100	180	860	0,1
6029PB	1000	1006	3	2	100	180	1060	0,1
6029PC	1200	1206	3	3	100	180	1260	0,1
6029PD	1400	1406	3	3	100	180	1460	0,1

Round manhole
Runde Klapptür

6029 R

AISI 304 - 316L

- ① frame - kragen
- ② cover - deckler
- ③ gasket - dichtung

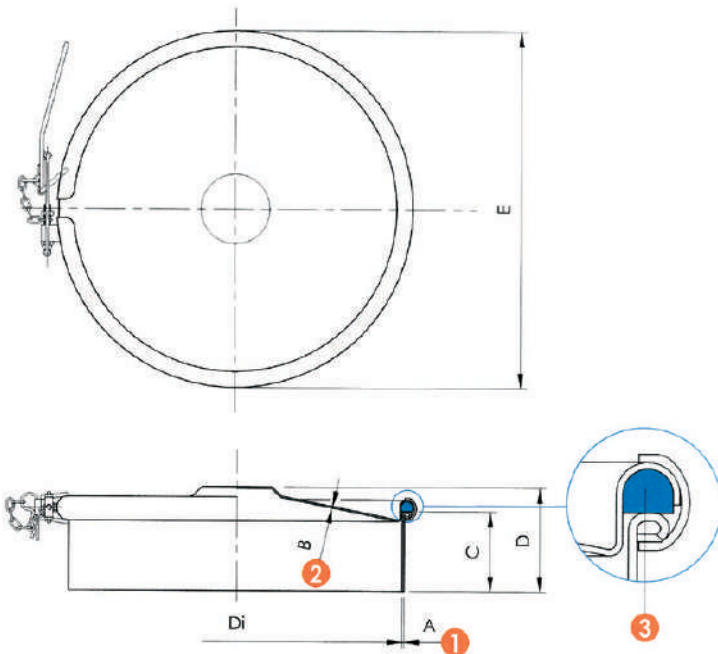

ART.	DN	Di	A	B	C	D	E	P _{bar} max	Vacuum _{bar}
6029R2	200	220	2	1,5	80	116	240	1,5	-0,5
6029R3	300	299	2	1,5	80	111	322	1,5	-0,5
6029R4	400	394	2	1,5	80	123	420	1	-0,5
6029R5	500	499	2	1,5	80	128	526	0,5	-0,5
6029R6	600	598	2	1,5	80	116	630	0,3	-0,3



Square manhole
Quadratische Klapptür

Frame for concrete vats
Für Betonfässer

6031

AISI 304 - 316L

- ① frame - kragen
- ② cover - deckler
- ③ gasket - dichtung
- ④ handwheel - handgriff
- ⑤ arm - schulter
- ⑥ stirrup - bügel

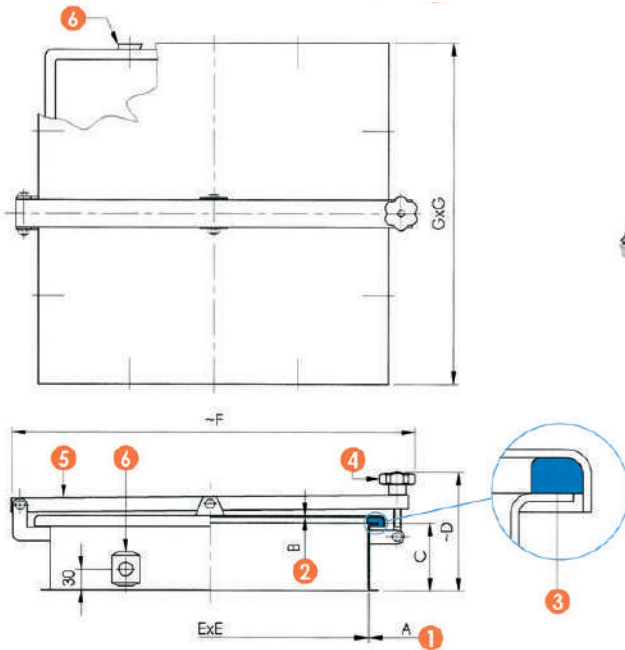

ART.	A	B	C	D	E	F	G	P. max bar
6031	2	2	100	181	450	577	499	0,01

Round manhole with flange for fixing in wooden tanks
Runde Klapptür mit Flansch für Holztanke, Deckel sietlich schwenkbar

6032

AISI 304 - 316L

- ① frame - kragen
- ② cover - deckler
- ③ gasket - dichtung
- ④ handwheel - handgriff

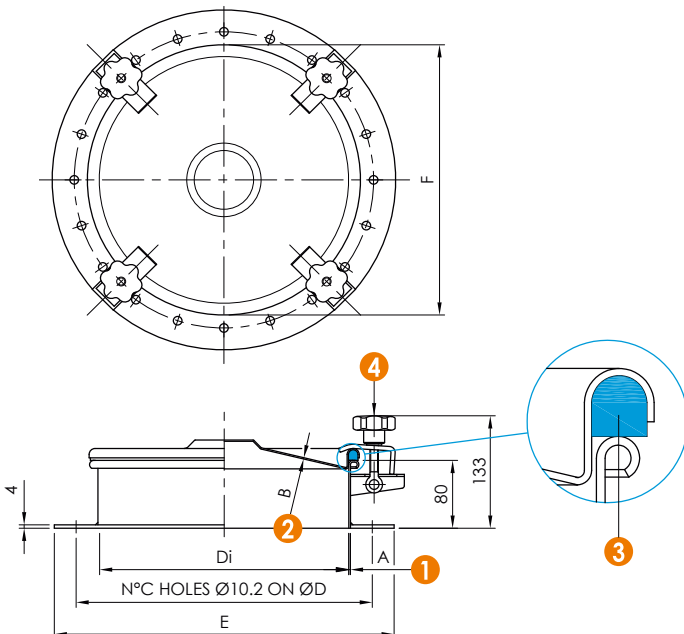

ART.	DN	Di	A	B	C	D	E	F	N°	P. max bar	Vacuum bar
6032	400	394	2	1,5	20	460	508	420	4	0,3	-0,05
6032 A	500	499	2	1,5	25	560	608	526	5	0,2	-0,05
6032 B	600	598	2	1,5	30	660	709	630	6	0,2	-0,03

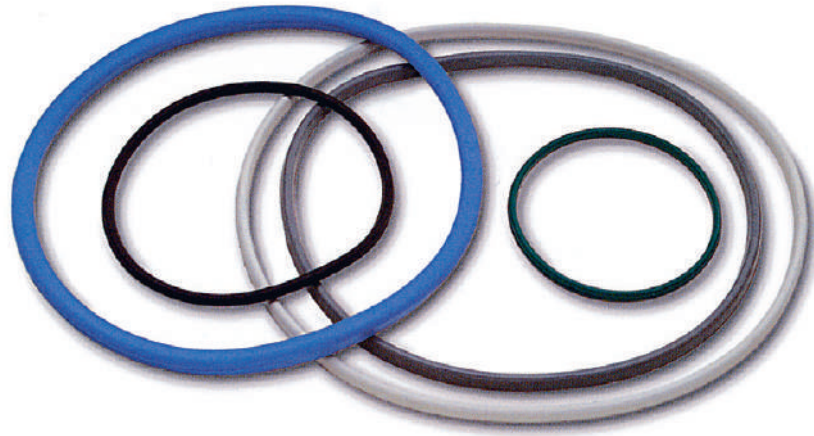

Gasket
Dichtungen

APPLICATION AND FEATURES FOR ELASTOMER SEAT

COMMERCIAL NAME	TECHNICAL NAME	GENERAL APPLICATIONS	TEMPERATURE LIMITS	NOT RECOMMENDED FOR
NBR	Copolymer of butadiene and high acrylonitrile	Hydrocarbons with less than 40% of aromatics, natural gas, air, wather, sea wather, brine, alcohols, glycols.	-20°C / +100°C -4°F / +212°F	solvents, benzene, xylene
ETHYLENE, PROPILENE HIGH. TEMP. (EPDM HT)	Terpolymer of ethylene and polypropylene	wather, steam, air brine, abrasives, phosphates, asters, ketones, alkali, food compounds, liquids and solids, dilute inorganics acids, caustic soda.	-35°C / +150°C -31°F / +302°F	hydrocarbons, solvents, steam
SILICONE Q	Methylvinil silicone	Beverages, foodstuffs	-30°C / +150°C -22°F / +302°F	hydrocarbons, solvents, steam
VITON* FPM	Copolymer of exafluoro propilene fluoro vinildene	Hydrocarbons with high concentracion of aromatics, mineral and halogenated acids, phosphoric acids, aliphatic and aromatic ethers.	-10°C / +160°C -14°F / +320°F	vapori, chetoni, ammine asteri, alcali
NEOPRENE* CR	Polichloroprene	Oils, diluite mineral acids, alkali, fats.	-18°C / +90°C 0°F / +194°F	ketones, concentrated acids, solvent for paint
NATURAL RUBBER (NR)	Latex (vegetable)	Corrosive products, solvents.	-35°C / +65°C -31°F / +149°F	abrasive products, fluorine gaseous, alkaline metals.
TEFLON* (P.T.F.E)	Polytetrafluoro ethylen	Corrosive products, solvents.	-40°C / +180°C -40°F / +356°F	abrasive products, flourine gaseous, alkaline metals

* - DU PONT

The above table is given as a guide only. Many factors can influence the extent of corrosion (type of solution - concentration - temperature - presence of impurities, ecc.). Hence it is up to the customer to make the final assessment depending on the application and equipment characteristics.



6036 V1

Bakelit handwheel M 10 - M 12
Bakelit Handrad M 10 - M 12

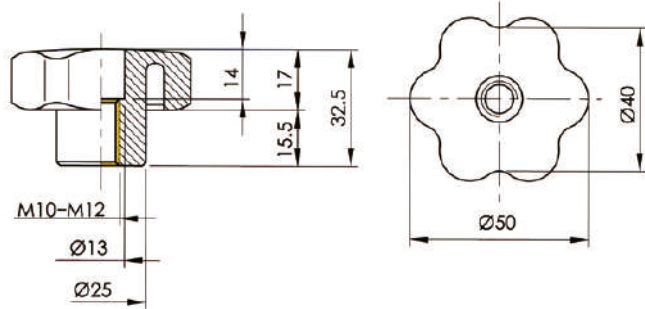

6036 V1/A

PVC handwheel M 10
PVC Handrad M 10

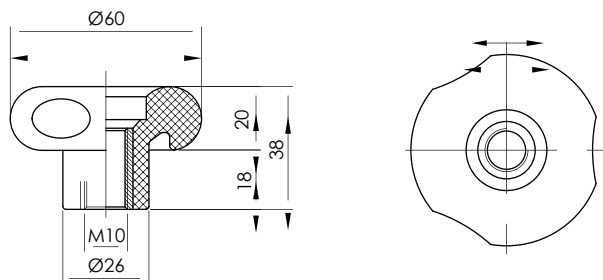

6036 V1/B

PVC handwheel with brake M 10 - M 12
PVC Handrad mit Bremse M 10 - M 12

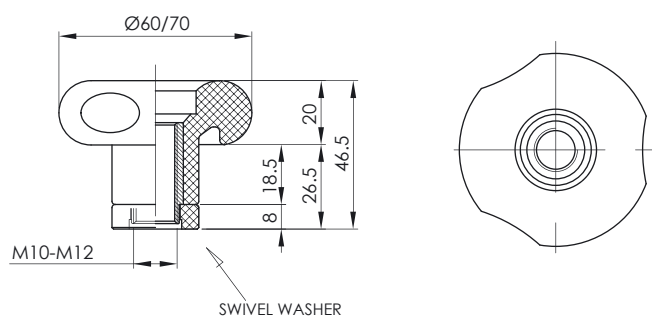

6036 V2

Stainless steel double hand nut with brass insert M12 - M14 - M18
Edelstahl Handgriff mit einer Messing-Beilage M12 - M14 - M18

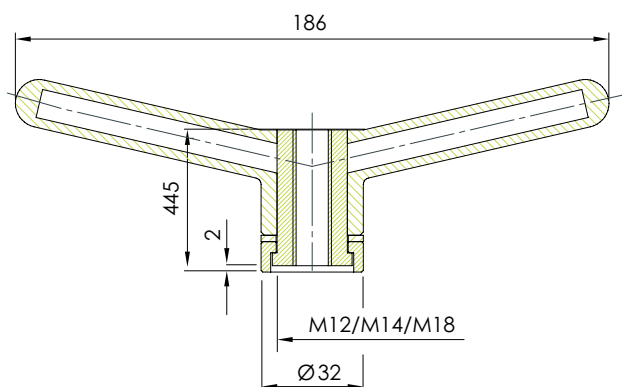



6036 V3

Technopolymer handwheel M 18
Technopolymer Handrad M 18

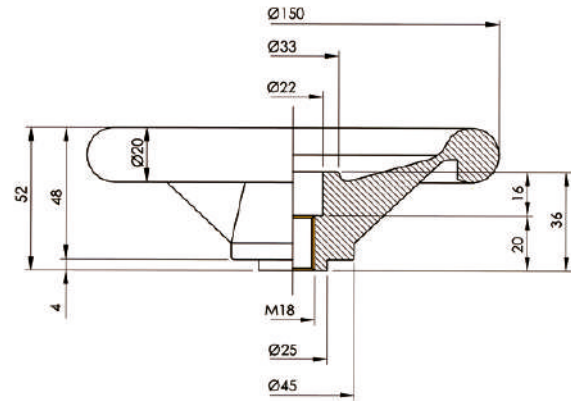

6036 V4

Stainless steel handwheel with brass insert M 10 - M 12
Edelstahl Handrad mit einer Messing-Beilage M 10 - M 12

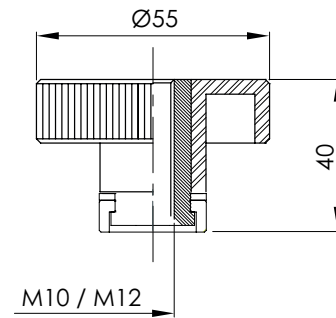

6036 V5

Stainless steel single hand nut M 14
Edelstahl Handgriff mit einer Messing-Beilage M 14

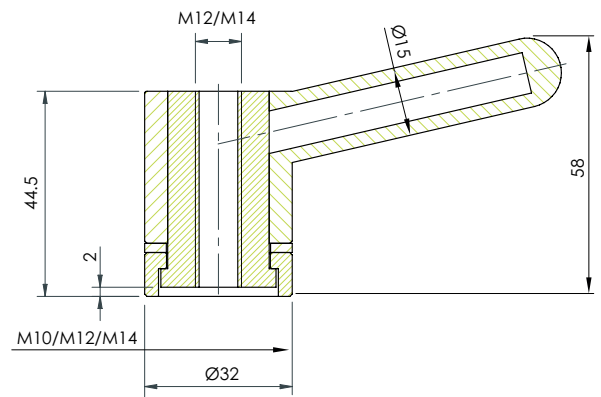

6036 V6

Stainless steel double hand nut TR 24 x 4
Edelstahl Handgriff TR 24 x 4

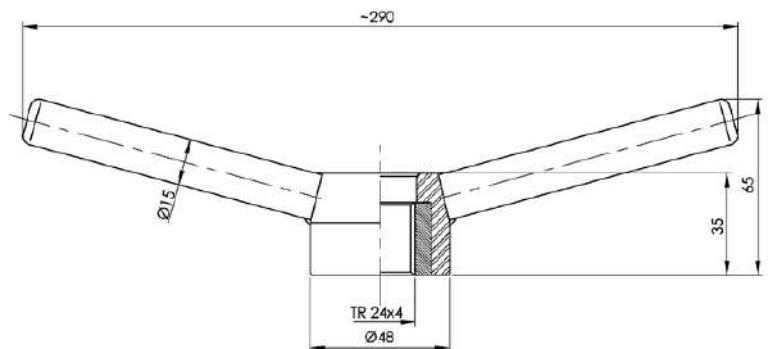



6036 V7

Stainless steel peripheral swing-bolts
Edelstahl Spannvorrichtung

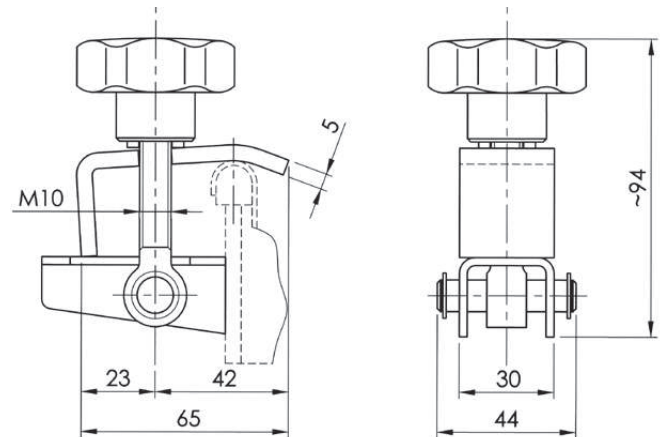

6036 V8

Stainless steel swing-bolt M 14
Edelstahl Bolzen M 14

TYPE	A	B	C
6036 V8 - 4 - 1	150	128	80
6036 V8 - 4 - 2	172	148	100
6036 V8 - 4 - 3	165	141	75
6036 V8 - 4 - 4	135	111	80
6036 V8 - 4 - 5	225	201	125

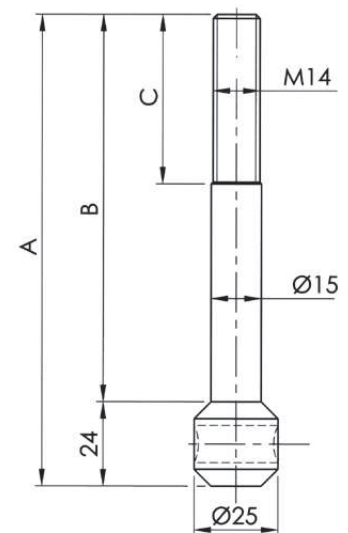

6036 V9

Stainless steel eye-bolt M 10 - M 12
Edelstahl Bolzen M 10 - M 12

TYPE	M	A	B	C	D	E
6036 V9 - 4 - 1	M 10	95	110	120	8,2	20
6036 V9 - 4 - 2	M 10	85	100	110	8,2	20
6036 V9 - 4 - 3	M 10	60	75	85	10,2	20
6036 V9 - 4 - 4	M 12	80	130	140,5	10,2	21
6036 V9 - 4 - 5	M 12	80	160	170,5	10,2	21

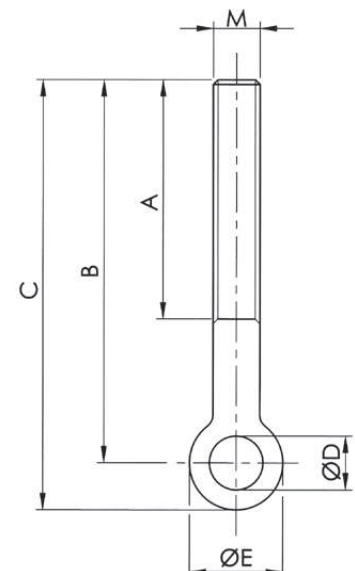

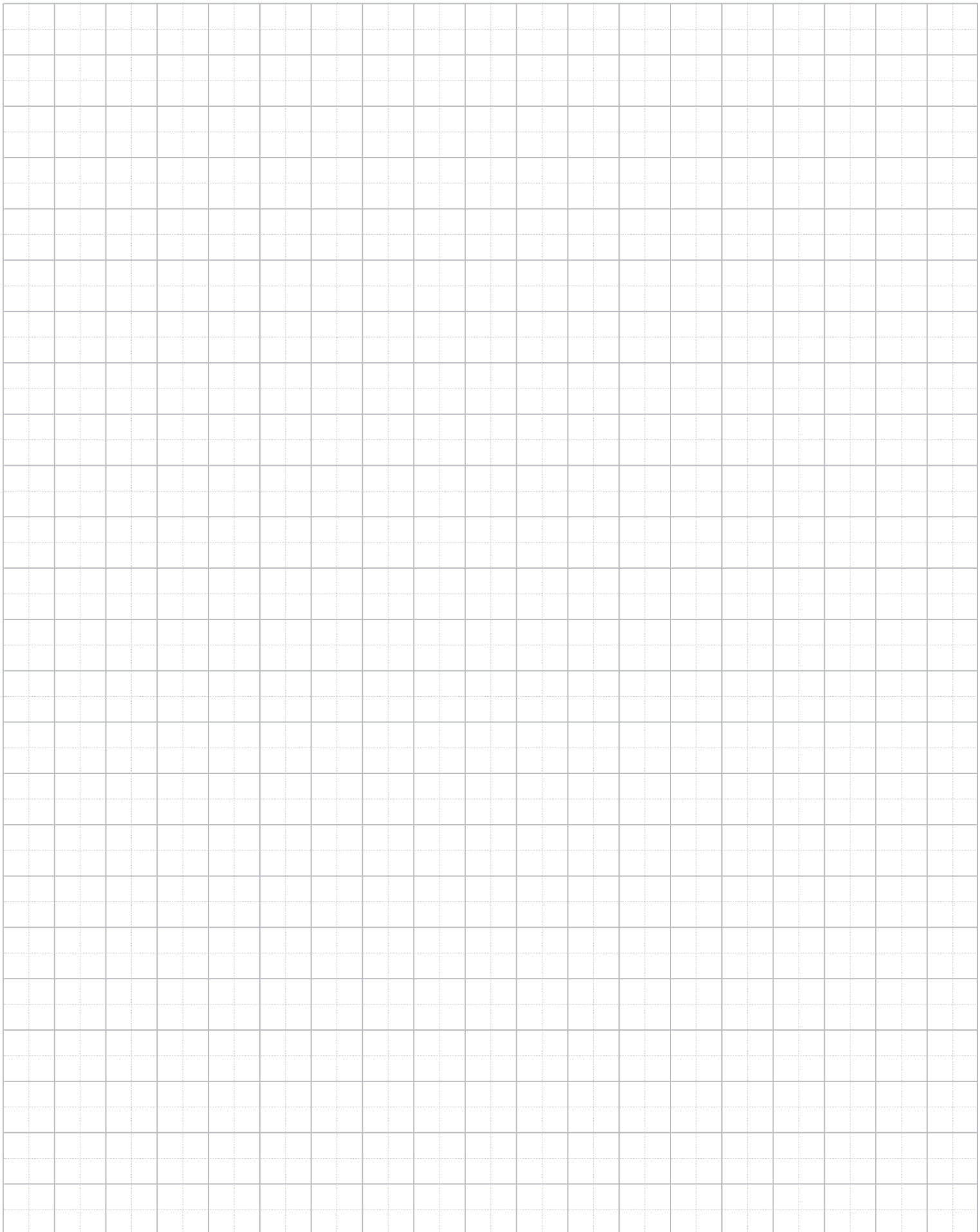

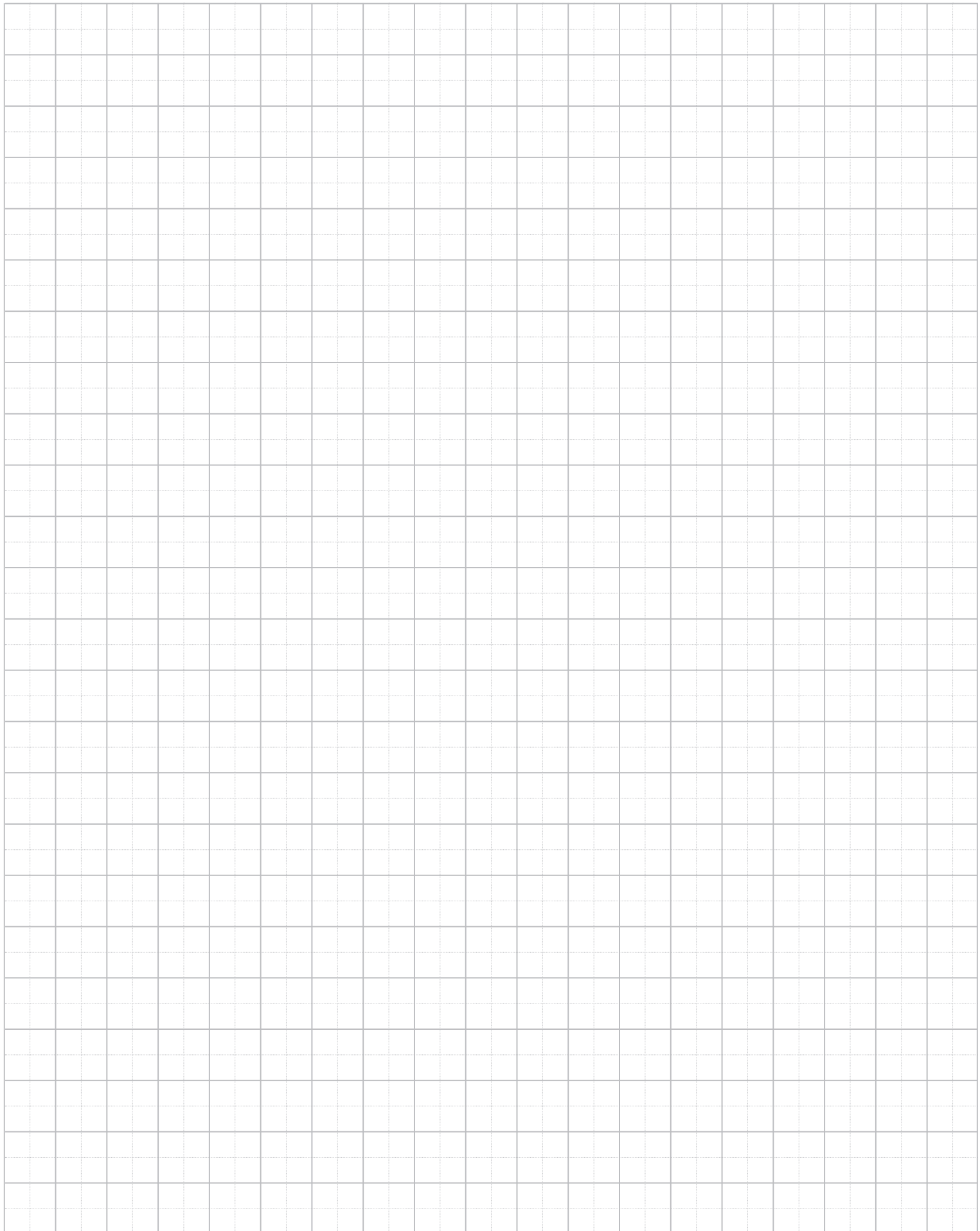



Technical Information for Gaskets					
Title	Silicon (VMQ silicon rubber)	EPDM (ethylene-propylene-diene rubber)	Viton (FPM fluorine rubber)	Perbunan (NBR nitrile rubber)	PTFE (polytetrafluorethylene)
Temperature of use	It is stable in water up to 100 °C Possibility of sterilisation by steam short-term up to 120 °C to 130 °C	Permanent operating use from 40 °C to +140 °C Possibility of sterilisation by steam up to 130 °C	Permanent operating use from 20 °C to +200 °C Possibility of sterilisation by steam short-term up to 130 °C to 140 °C	Permanent operating use from 25 °C to +110 °C Possibility of sterilisation by steam short-term up to 130 °C	Up to +200 °C it is physiologically harmless, use from 200 °C to +260 °C
Recommended use	High temperature load capacity It has good resistance to cold, suitable for food, it has dielectric properties. It has good resistance to alcohols.	It has good resistance to swelling for: • Diluted inorganic and organic acids, media, oxidising media, lyes, and ketones • Hot water and steam up to 130 °C	It has good resistance to swelling for: • Mineral oils • Plant and animal oils • Lubricants (also some additives) • Fuels	It has good resistance to swelling for: • Aliphatic hydrocarbons (such as propane, butane, benzene, mineral oil) • Lubricants based on mineral oil	It has good resistance to swelling in almost all parts. It has a smooth and repellent surface so sticking does not occur. It has better chemical resistance than in all other elastomers Non-flammable material
Limited use (border)	Shows high swelling for: • Low-molecular esters and ethers • Aliphatic and aromatic hydrocarbons • Concentrated acids and alkali	Cannot be used for: • Plant and animal oils • Aliphatic, aromatic, and chlorinated hydrocarbons • Mineral oils	Shows high swelling for: • Polar solvents, such as acetone, methyl ketone, ethyl acetate, diethyl ether, and dioxane • Low-molecular organic acids (formic acid and acetic acid) • Gaseous ammonia, amines and alkanes • Overheated water steam	Not resistant to: • Polar solvents • Chlorinated hydrocarbons • Ketones • Aromatic hydrocarbons (benzol) • Esters	Not resistant to: • Liquid alkaline metals and some compounds of fluorine in connection with higher pressure and temperature The material does not show the flexibility of rubber.
Material approval	BGA/FDA	BGA/FDA	BGA/FDA	BGA/FDA	BGA/FDA
BGA = approval of the "Federal Health Authority" in Germany ("Bundesgesundheitsamt") FDA = approval of the "US Food and Drug Administration"					



Technische Informationen für Dichtringe					
Name	Silikon (VMQ)	EPDM (Ethylen-Propylen-Dien-Kautschuk)	Viton (FPM)	Perbunan (NBR)	PTFE (Polytetrafluoräthylen)
Einsatztemperatur	in Wasser bis 100°C beständig Dampfsterilisierbar kurzfristig bis 120°C - 130°C	Dauereinsatz von minus 40°C bis 140°C Dampfsterilisierbar bis 130°C	Dauereinsatz von minus 20°C bis 200°C Dampfsterilisierbar kurzfristig bis 130°C - 140°C	Dauereinsatz von minus 25°C bis 110°C Dampfsterilisierbar kurzfristig bis 130°C	bis 200°C physiologisch unbedenklich, Einsatz von -200°C bis +260°C
typ. Einsatzbereich	hohe thermische Belastbarkeit gute Kältebeständigkeit, für lebensmittel gut geeignet, dielektrische Eigenschaften gute Beständigkeit gegenüber Alkoholen	gute Quellbeständigkeit bei: • verdünnte anorg.- und organische Säuren, Medien, oxidierend wirkende Medien, Laugen und Kationen • in Heißwasser und Dampf bis 130°C	gute Quellbeständigkeit bei: • Mineralölen • pflanzlichen und tierischen Ölen • Fetten (auch bestimmte Additive) • Kraftstoffe	gute Quellbeständigkeit • aliphatischen Kohlenwasserstoffen (wie Propan, Butan, Benzin, Mineralölen) • Fett auf Mineralölbasis	gute Quellbeständigkeit in nahezu allen Teilen Oberfläche glatt und abweisend, dadurch kein Haften von Rückständen chemische Beständigkeit besser als bei allen anderen Elastomeren kaum brennbar
Einsatzgrenzen	hohe Quellung bei: • niedermolekularen Estern und Ethern • aliphatischen und aromatischen Kohlenwasserstoffen • konz. Säuren und Alkalien	nicht einzusetzen bei: • pflanzlichen und tierischen Ölen • aliphatischen aromatischen und chlorierten Kohlenwasserstoffen • Mineralöle	stark quellend bei: • polaren Lösungsmitteln wie Aceton, Methylketon, Ethylacetat, Diethylether u. Dioxane • niedermolekularen organ. Säuren (Ameisen- und Essigsäuren) • Ammoniakgase, Amine u. Alkanien • überhitzter Wasserdampf	nicht beständig bei: • polaren Lösungsmitteln • chlorierten Kohlenwasserstoffen • Ketone • Aromaten (Benzol) • Ester	nicht beständig bei: • flüssigen Alkalimetallen und einigen Flourverbindungen in Verbindung mit hohem Druck und Temperatur kein gummielastischer Werkstoff
Werkstoffzulassung	BGA/FDA	BGA/FDA	BGA/FDA	BGA/FDA	BGA/FDA
BGA = Bundesgesundheitsamt FDA = US Food and Drug Administration					



CONVERSION TABLE		UMRECHNUNGSTABELLE	
DN	(inch)	(mm)	
8	1/4"	6,35	
10	3/8"	9,25	
15	1/2"	12,7	
20	3/4"	19,0	
25	1"	25,4	
32	1 1/4"	31,7	
40	1 1/2"	38,1	
50	2"	51,0	
65	2 1/2"	63,5	
80	3"	76,1	
100	4"	104,0	

BAR CONVERSION CHARTS	BAR UMPRECHNUNGSTABELLE
<h1>1 Bar</h1>	100000 Pascals
	100 Kilopascals
	1000 Milibars
	1000000 Microbars
	~0,98 Atmospheres
	~401,46 Inches of wather
	10 Meters of wather
	~29,53 Inches of mercury
	~750 Milimeters of mercury
	~14,5 Pounds per square inches
	~1,02 Kilograms per square inches



PRODUCER OF STAINLESS PIPING SYSTEMS
HERSTELLER VON EDELSTAHLARMATUREN

NIOB FLUID s. r. o.

Ostrožská 1003
687 25 Hluk
Czech Republic

Phone: +420 572 419 822 - 8
Fax: +420 572 419 868
E-mail: marketing@niobfluid.cz

www.niobfluid.cz